

REV	ECN	DESCRIPTION	DATE	MODIFIED
C	C3520N	CHANGE THE STRUCTURE	2019.9.10	

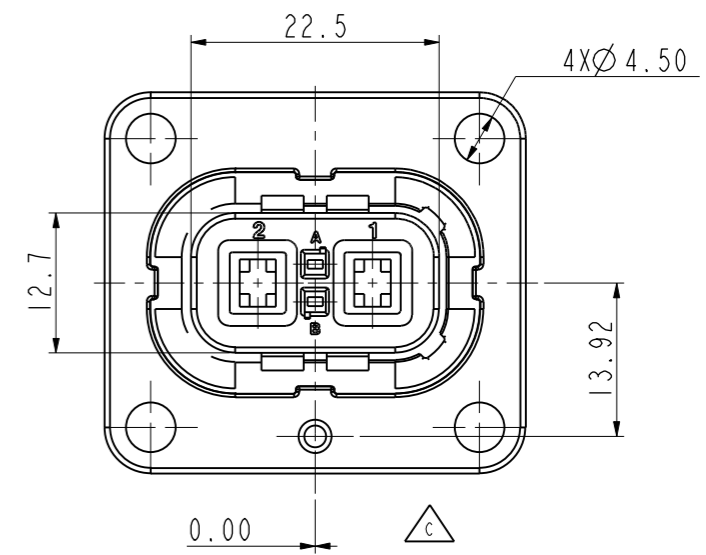
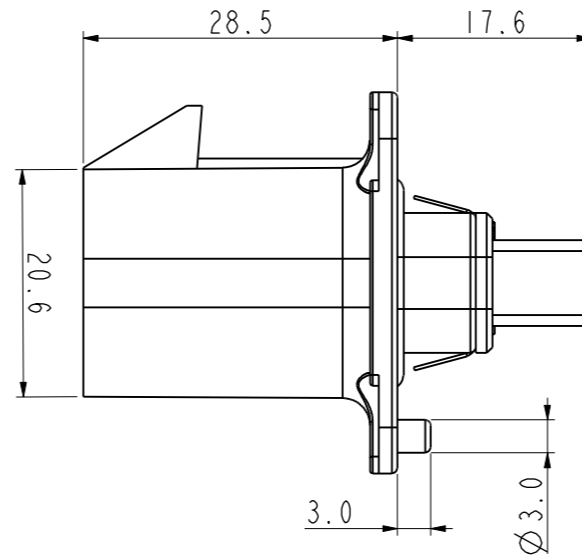
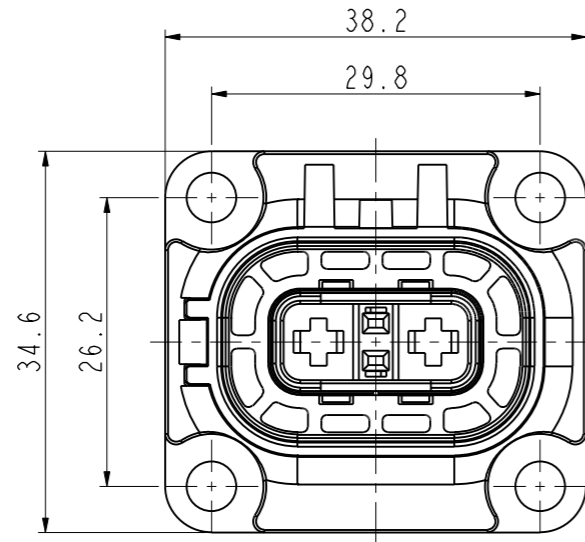
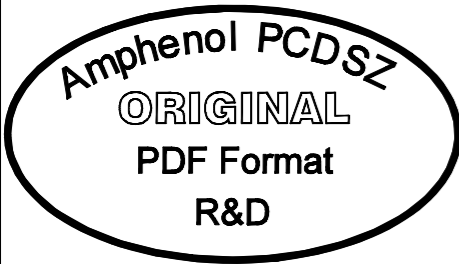

NOTE:

- △ 1.RECEPTACLE DON'T INCLUDE CONTACT PIN,NEED TO BUY SEPARATE:
THE MAIN CONTACT:C310003611S,USE LEVEL: 2PCS
THE HVIL CONTACT:C310003614S,USE LEVEL: 2PCS
- 2.PREVAILING TORQUES:2~3N*M
- ✦ 3.ROHS COMPLIANCE 符合RoHS

安费诺精密连接器(深圳)有限公司
Amphenol PCD Shenzhen
受控文件
2020年3月27日

SCOPE OF CABLE OUTSIDE DIAMETER	
SIZE	OUTSIDE DIAMETER
2.5 MM ²	2.7~3.7 MM
3 MM ²	2.7~3.7 MM
4 MM ²	3.0~4.0 MM

C-HVSLM282022A

- ✦ :CRITICAL CHARACTERISTICS 关键特性
- ◎ :IMPORTANT CHARACTERISTICS 重要特性

TECHNICAL DATA		
CURRENT RATE (4MM ² UNSHIELD CABLE)	32A @ AMBIENT 70° C	✦
CURRENT RATE (2.5~3MM ² UNSHIELD CABLE)	23A @ AMBIENT 70° C	✦
UL RATING VOLTAGE (OVERVOLTAGE CATEGORY II POLLUTION DEGREE 2)	800V DC	✦
OPERATING TEMPERATURE	-40~125° C	
DIELECTRIC WITH STANDING VOLTAGE	2600V AC	✦
INSULATION RESISTANCE	100MΩ MIN.	✦
DURABILITY	50 CYCLES	◎
SHIELDING	YES	
WATERPROOF (MATED CONDITION)	IP 67、IP6K9K	✦
PROTECTION LEVEL	IP2XB	✦
AMBIENT TEMPERATURE	-40~70° C	

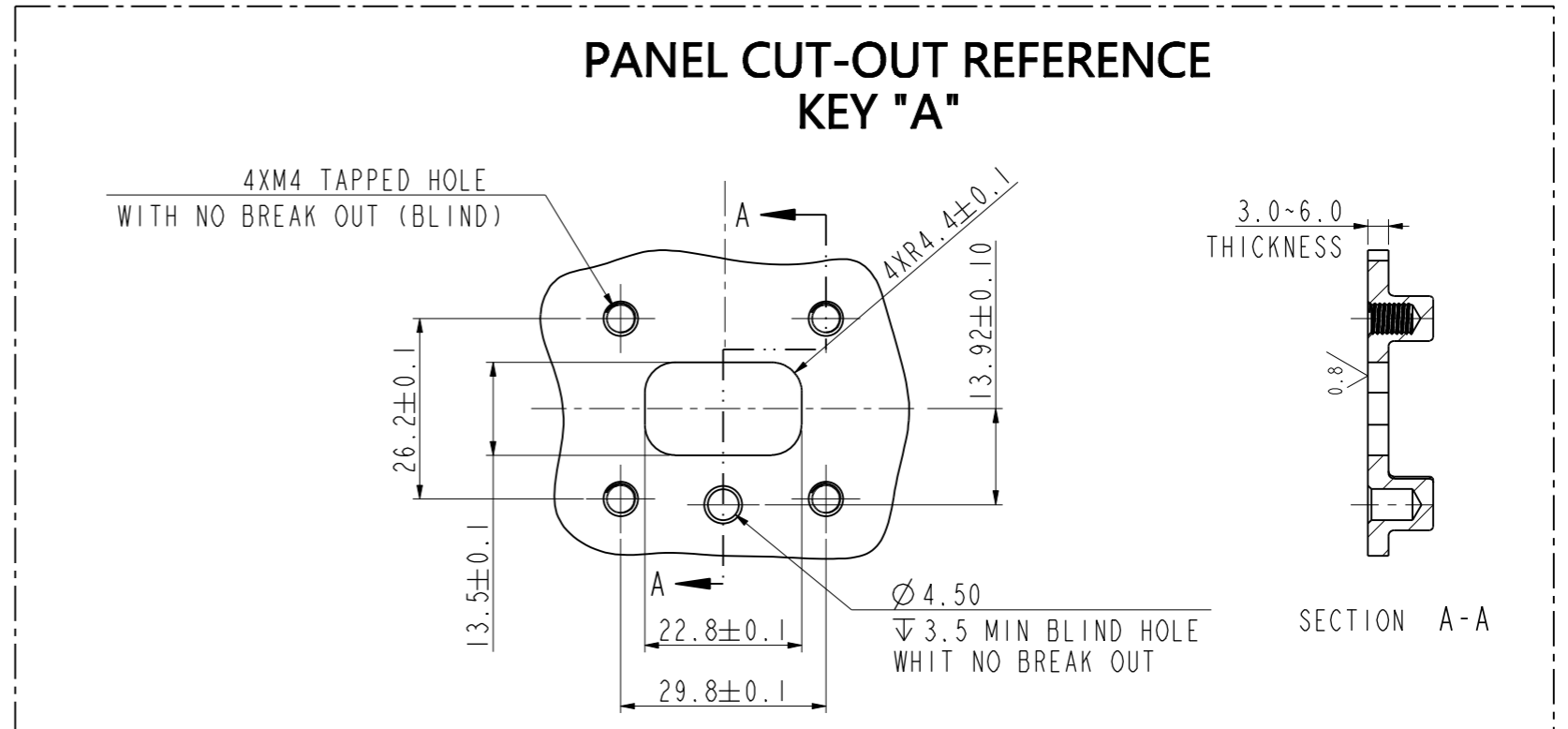

C-HVSLM282022A

DIMENSIONS	TOLERANCES	PROJECTION	TITLE		
ANSI Y14.5M UNITS: MM Pro/E FILE	X ±0.5 XX ±0.05 ANGLES ±0.5°		HVSLM282 RECEPTACLE		
ORIGINAL	THIS DOCUMENT CONTAINS PROPRIETARY INFORMATION WHICH IS THE CONFIDENTIAL PROPERTY OF AMPHENOL PCD SHENZHEN				
			CHKD	APPD	SIZE A3
					DWG NO. C-HVSLM282022A
					REV C
					CODE: 58982
					SCALE: 2:1
					SHEET 1 OF 1