

C-HVSL600061XXXXXX

REV	ECN	DESCRIPTION	DATE	MODIFIED
A		RELEASE	18/07/19	
B		CHANGE THE SPEC	2019.04.22	
C	C3899N	CHANGE THE POWER&HVIL PIN PN	2019.11.20	
D	R4025W	CHANGE THE FERRULE P/N	2020.1.11	
E	R4768N	CHANGE THE RATING VOLTAGE	2020.9.21	

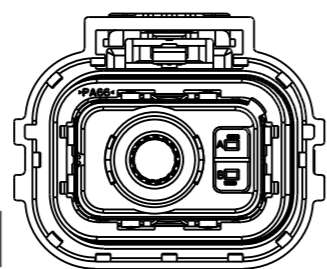

KEY C
C-HVSL610 06 I C X XX XX

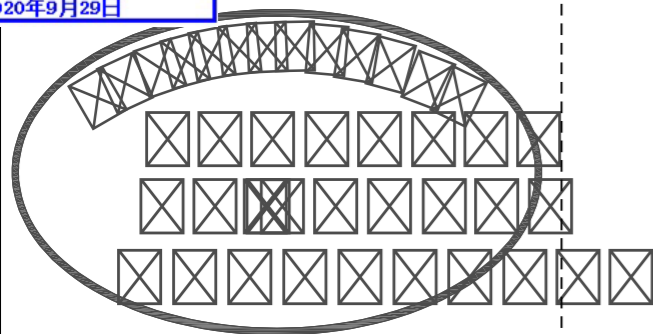
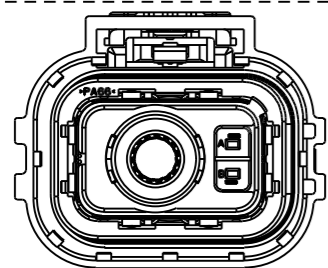
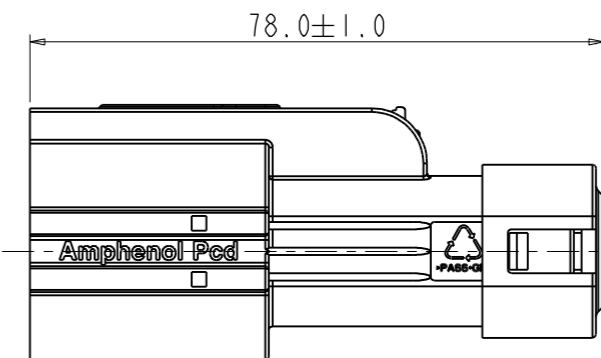
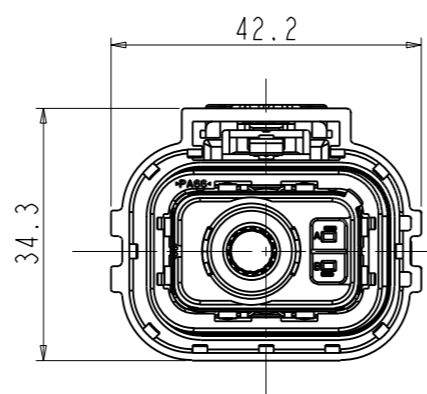

KEY A
C-HVSL600 06 I A X XX XX

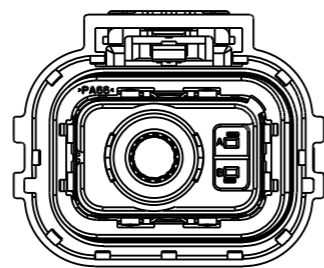

KEY D
C-HVSL600 06 I D X XX XX

TECHNICAL DATA			
CURRENT RATE	SIGNAL CONTACT: 5A (0.5~0.75mm ² : OUTSIDE DIAMETER ϕ 1.4~1.9mm)	+	△ E
UL RATING VOLTAGE (OVERVOLTAGE CATEGORY II POLLUTION DEGREE 2)	POWER CONTACT: 120A (25mm ²)		
WITHSTANDING VOLTAGE	POWER CONTACT: 1000V DC	+	△ E
	POWER CONTACT: 3000V AC		
INSULATION RESISTANCE	SIGNAL CONTACT: 660V AC	+	△ E
	100 M Ω min		
WATERPROOF (MATED CONDITION)	IP 67, IP6K9K	+	
IP FOR FINGER TOUCH (UNMATED CONDITION)	IP2XB	+	
SHIELDING FUNCTION	YES		
MAX MATING CYCLES	50 TIMES	◎	
OPERATING TEMPERATURE	-40~125 C		

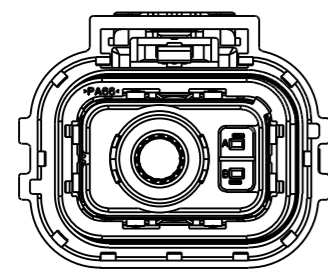

KEY B
C-HVSL600 06 I B X XX XX

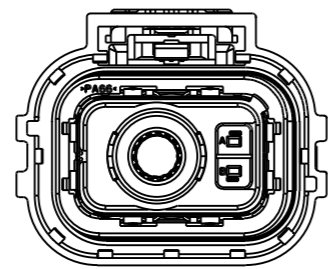

KEY E
C-HVSL600 06 I E X XX XX

NOTES:

1. MATERIAL & FINISH:

PLASTIC BODY: THERMOPLASTICS PA66+GF25 ORANGE COLOR
POWER CONTACTS: COPPER ALLOY WITH AG PLATED
HVIL CONTACTS: COPPER ALLOY WITH TIN PLATED
SHIELD: COPPER ALLOY WITH TIN PLATED
SEAL: SILICONE

2. TECHNICAL DATA SHEET: APCD-TD-311

3. PART NUMBER DESCRIPTION:

HVSL 600 06 I X X XX XX

CODE:	HVIL:	WIRE SIZE:	CABLE OD:
A: CODING A	0: WITHOUT HVIL	25: 25mm ²	10: 10±0.5mm
B: CODING B	1: WITH HVIL		11: 11±0.5mm
C: CODING C			12: 12±0.5mm
D: CODING D			13: 13+0/-0.5mm
E: CODING E			

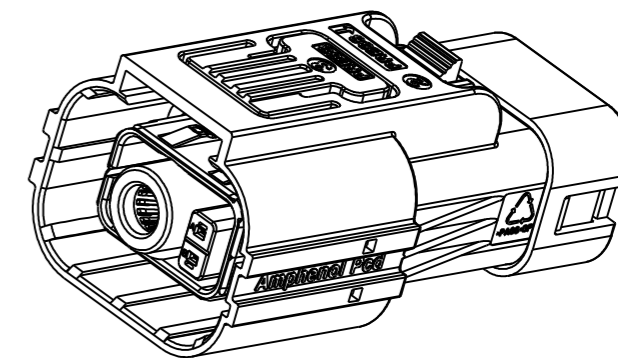

+ CRITICAL CHARACTERISTIC MARKS / 关键特性符号
◎ IMPORTANT CHARACTERISTIC MARKS / 重要特性符号

DIMENSIONS	TOLERANCES	PROJECTION	TITLE		
ANSI Y14.5M UNITS: MM Pro/E FILE	X ±0.5 .XX ±0.05 ANGLES ±0.5°		HVSL630 PLUG ASSEMBLY		
ORIGINAL	THIS DOCUMENT CONTAINS PROPRIETARY INFORMATION WHICH IS THE CONFIDENTIAL PROPERTY OF AMPHENOL PCD SHENZHEN		ENGR	Celine	18/07/19
			CHKD		
			SIZE	DWG NO.	REV
			A3	C-HVSL600061XXXXXX	E
			CODE: 58982	SCALE: 0.9:1	SHEET 1 OF 3

C-HVSL600061XXXXXX

C-HVSL600061XXXXXX

C-HVSL600061XXXXXX

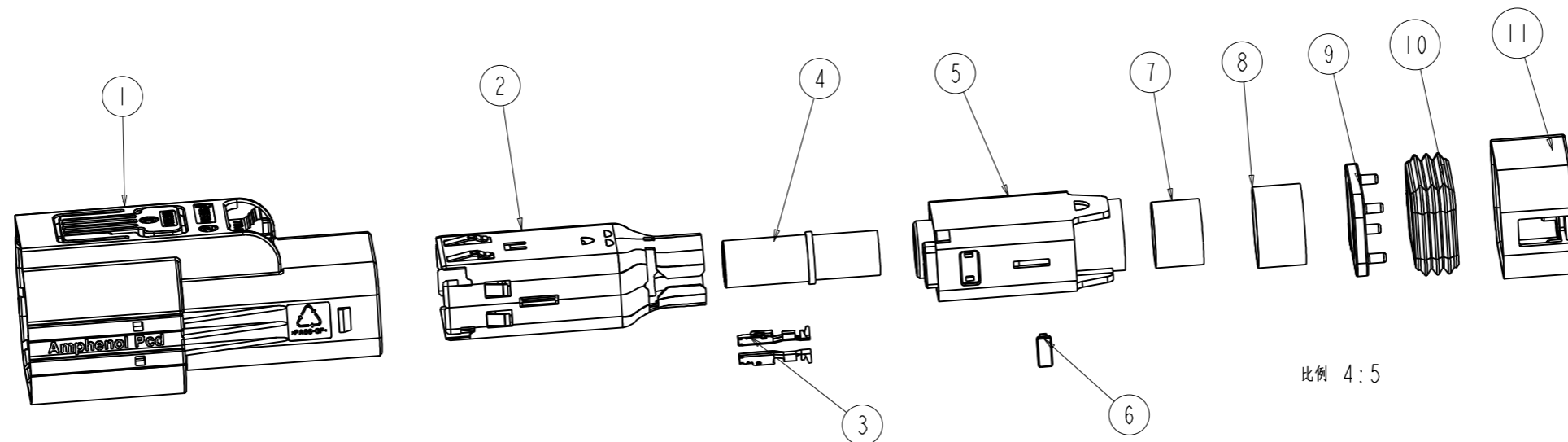

比例 4:5

HVSL60006X SELECTION:

HVSL60006A	KEY A
HVSL60006B	KEY B
HVSL60006C	KEY C
HVSL60006D	KEY D
HVSL60006E	KEY E

HVSL600 06 1 X 1 25 10	11	C220003620	END CAP	1
	10	C2700036072	CABLE SEAL (CABLE OD: ϕ 10mm)	1
	9	C220003622	SPACER	1
	8	P03BM00117	OUTER FERRULE	1
	7	P03BM00388	INNER FERRULE	1
	6	C220003657	TPA 2	1
	5	C422003654	TPA 1	1
	4	C420003620	MAIN CONTACT (25mm ²)	1
	3	C310003614S	HVIL CONTACT (0.5~0.75mm ²)	2
	2	C310003609	SHIELD	2
	1	HVSL60006X	PLUG (KEY A/B/C/D/E)	1

HVSL600 06 1 X 1 25 11	11	C220003620	END CAP	1
	10	C2700036071	CABLE SEAL (CABLE OD: ϕ 11mm)	1
	9	C220003622	SPACER	1
	8	P03BM00117	OUTER FERRULE	1
	7	P03BM00388	INNER FERRULE	1
	6	C220003657	TPA 2	1
	5	C422003654	TPA 1	1
	4	C420003620	MAIN CONTACT (25mm ²)	1
	3	C310003614S	HVIL CONTACT (0.5~0.75mm ²)	2
	2	C310003609	SHIELD	2
	1	HVSL60006X	PLUG (KEY A/B/C/D/E)	1
ASSEMBLY P/N	ITEM	P/N	DESCRIPTION	Q'TY

HVSL600 06 1 X 1 25 12 HVSL600 06 1 X 1 25 13	11	C220003620	END CAP	1
	10	C270003607	CABLE SEAL (CABLE OD: ϕ 12mm) (CABLE OD: ϕ 13mm)	1
	9	C220003622	SPACER	1
	8	P03BM00117	OUTER FERRULE	1
	7	P03BM00388	INNER FERRULE	1
	6	C220003657	TPA 2	1
	5	C422003654	TPA 1	1
	4	C420003620	MAIN CONTACT (25mm ²)	1
	3	C310003614S	HVIL CONTACT (0.5~0.75mm ²)	2
	2	C310003609	SHIELD	2
	1	HVSL60006X	PLUG (KEY A/B/C/D/E)	1
ASSEMBLY P/N	ITEM	P/N	DESCRIPTION	Q'TY

C-HVSL600061XXXXXX

C-HVSL600061XXXXXX

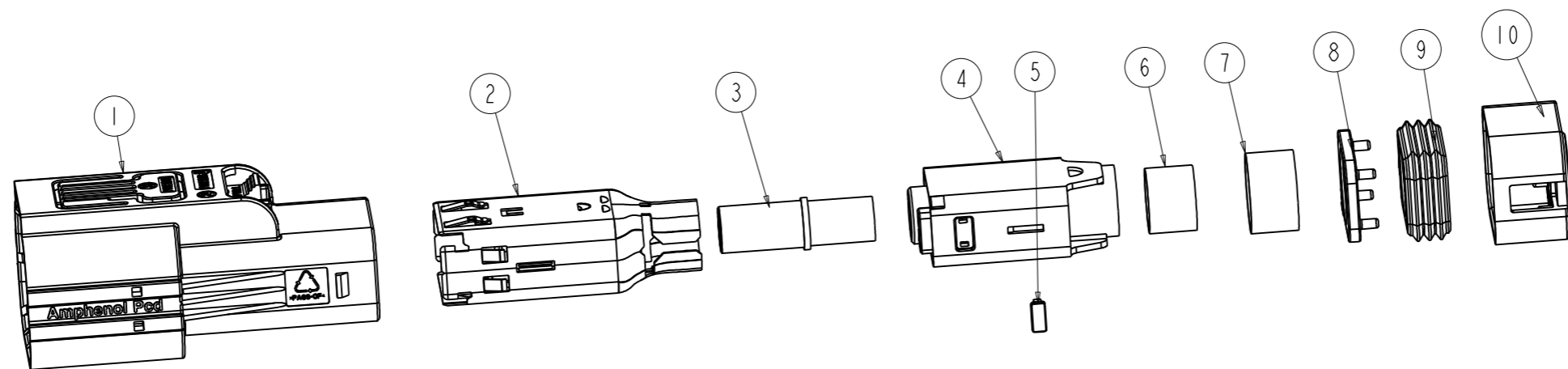

比例 4:5

HVSL600 06 1 X 0 25 10	10	C220003620	END CAP	1
	9	C2700036072	CABLE SEAL (CABLE OD: ϕ 10mm)	1
	8	C220003622	SPACER	1
	7	P03BM00117	OUTER FERRULE	1
	6	P03BM00388	INNER FERRULE	1
	5	C220003657	TPA 2	1
	4	C422003654	TPA 1	1
	3	C420003620	MAIN CONTACT (25mm ²)	1
	2	C310003609	SHIELD	2
	1	HVSL60006X	PLUG (KEY A/B/C/D/E)	1

HVSL60006X SELECTION:

HVSL60006A	KEY A
HVSL60006B	KEY B
HVSL60006C	KEY C
HVSL60006D	KEY D
HVSL60006E	KEY E

HVSL600 06 1 X 0 25 11	10	C220003620	END CAP	1
	9	C2700036071	CABLE SEAL (CABLE OD: ϕ 11mm)	1
	8	C220003622	SPACER	1
	7	P03BM00117	OUTER FERRULE	1
	6	P03BM00388	INNER FERRULE	1
	5	C220003657	TPA 2	1
	4	C422003654	TPA 1	1
	3	C420003620	MAIN CONTACT (25mm ²)	1
	2	C310003609	SHIELD	2
	1	HVSL60006X	PLUG (KEY A/B/C/D/E)	1
ASSEMBLY P/N	ITEM	P/N	DESCRIPTION	Q'TY

HVSL600 06 1 X 0 25 12	10	C220003620	END CAP	1
	9	C270003607	CABLE SEAL (CABLE OD: ϕ 12mm) (CABLE OD: ϕ 13mm)	1
	8	C220003622	SPACER	1
	7	P03BM00117	OUTER FERRULE	1
	6	P03BM00388	INNER FERRULE	1
	5	C220003657	TPA 2	1
	4	C422003654	TPA 1	1
	3	C420003620	MAIN CONTACT (25mm ²)	1
	2	C310003609	SHIELD	2
	1	HVSL60006X	PLUG (KEY A/B/C/D/E)	1
ASSEMBLY P/N	ITEM	P/N	DESCRIPTION	Q'TY

C-HVSL600061XXXXXX

C-HVSL600061XXXXXX