

REV	ECN	DESCRIPTION	DATE	MODIFIED
1		PRE- RELEASE	Jun-25-23	

Amphenol PCD SZ
ORIGINAL
PDF Format
R&D

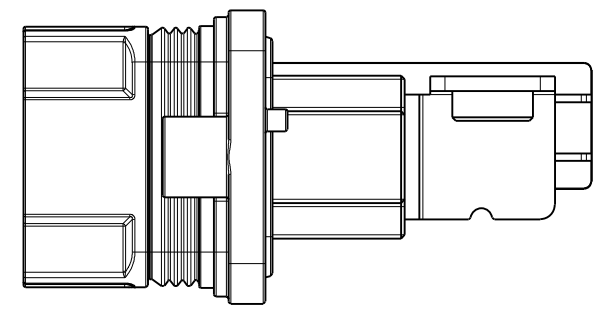
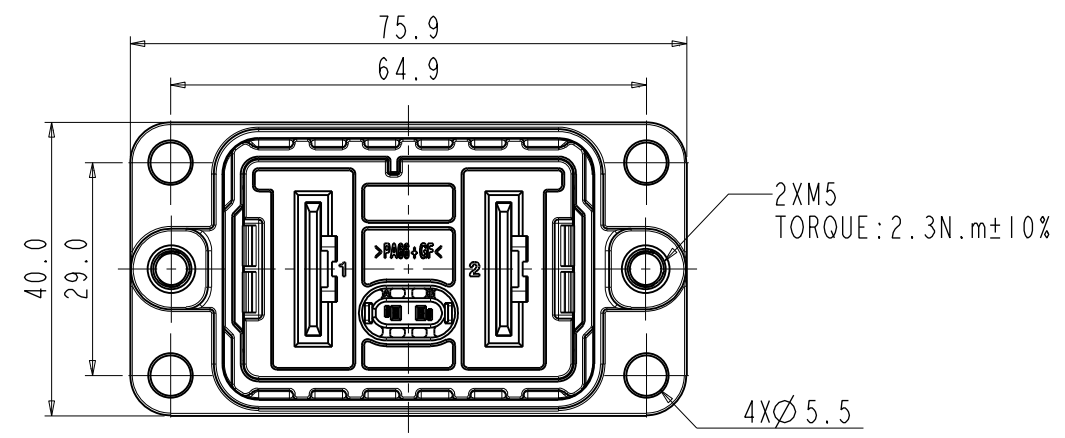
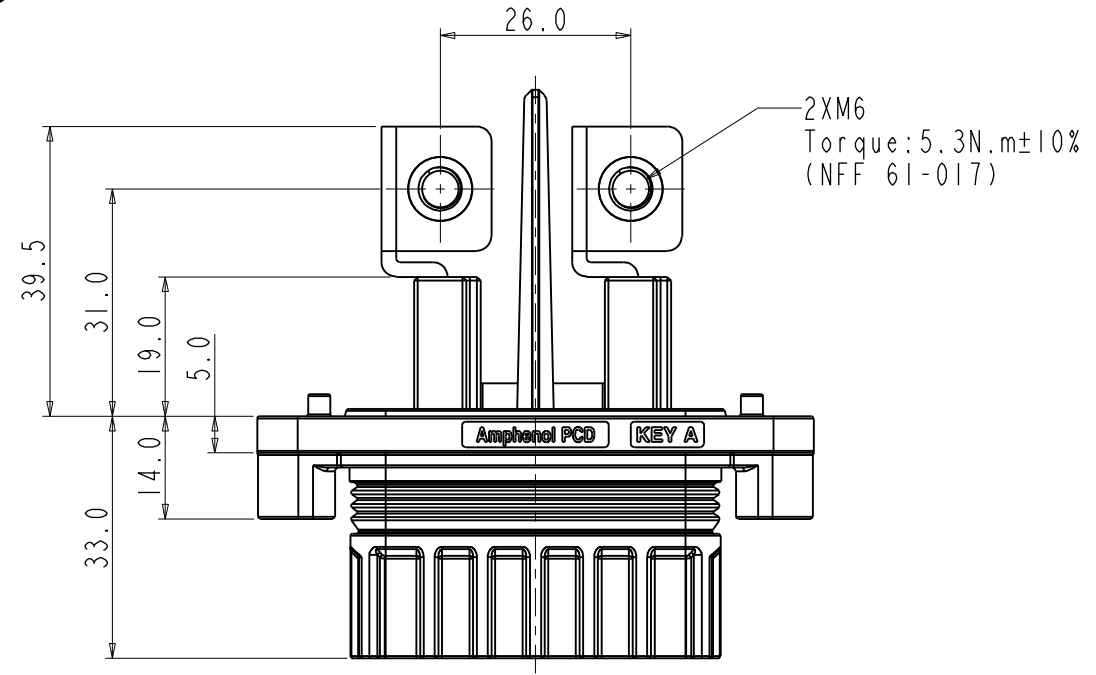

TECHNICAL DATA		
CURRENT RATE 70MM ² WIRE	250A	★
CURRENT RATE 50MM ² WIRE	200A	★
CURRENT RATE 35MM ² WIRE	150A	★
SIGNAL CURRENT	5A MAX	★
VOLTAGE RATE	POWER: 1000V DC	★
OPERATING TEMPERATURE	-40-125°C	NA
DIELECTRIC WITHSTANDING VOLTAGE	POWER: 3000V AC	★
	SIGNAL: 660V AC	
INSULATION RESISTANCE	>100M Ω	★
DURABILITY	50 CYCLES	◎
SHIELDING	YES	NA
WATERPROOF(MATED CONDITION)	IP67 IP6K9K	★
UNMATED CONDITION	IP2XB	★
CORROSION-PROFF GRADE(SALT FOG TEST)	336 HOURS	NA
AMBIENT TEMPERATURE	-40-70°C	NA

APPLICATION:
 POLLUTION DEGREE 2 / 污染等级 2
 OVERVOLTAGE CATEGORY II / 过电压类别 II
 INHOMOGENEOUS FIELD / 非均匀电场
 ALTITUDE NO MORE THAN 4000M / 海拔不高于4000M
 ★ IS CRITICAL CHARACTERISTIC SYMBOL
 ◎ IS IMPORTANT CHARACTERISTIC SYMBOL

HVPC18022 X X XX S01

H6:M6 NUT

0: Without signal
1: With signal

A: A key
B: B key
C: C key

DIMENSIONS	TOLERANCES	PROJECTION	TITLE		
ANSI Y14.5M UNITS: MM Pro/E FILE	.X ± 0.5 .XX ± 0.05 ANGLES $\pm 2^\circ$		HVPC18 RECEPTACLE SHORT CONTACT		
ORIGINAL	THIS DOCUMENT CONTAINS PROPRIETARY INFORMATION WHICH IS THE CONFIDENTIAL PROPERTY OF Amphenol PCD Shenzhen Co. Ltd Amphenol PCD Shenzhen Co. Ltd RESERVES THE RIGHT TO CLARIFY THIS DRAWING				
			CHKD	SIZE	DWG NO.
			APPD	A3	C-HVPC18022XXXXS01
				SCALE: 1:1	REV 1
				SHEET 1	OF 4

C-HVPC18022XXXXS01

C-HVPC18022XXXXS01

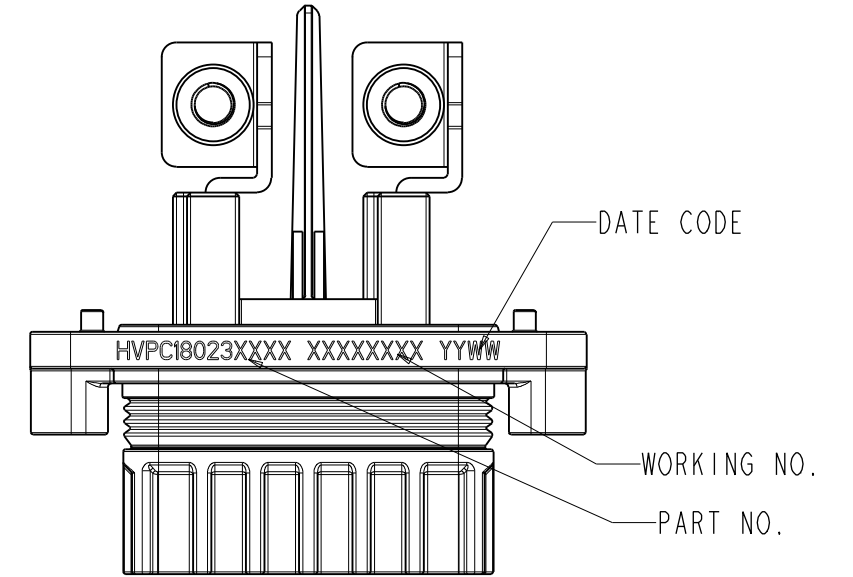
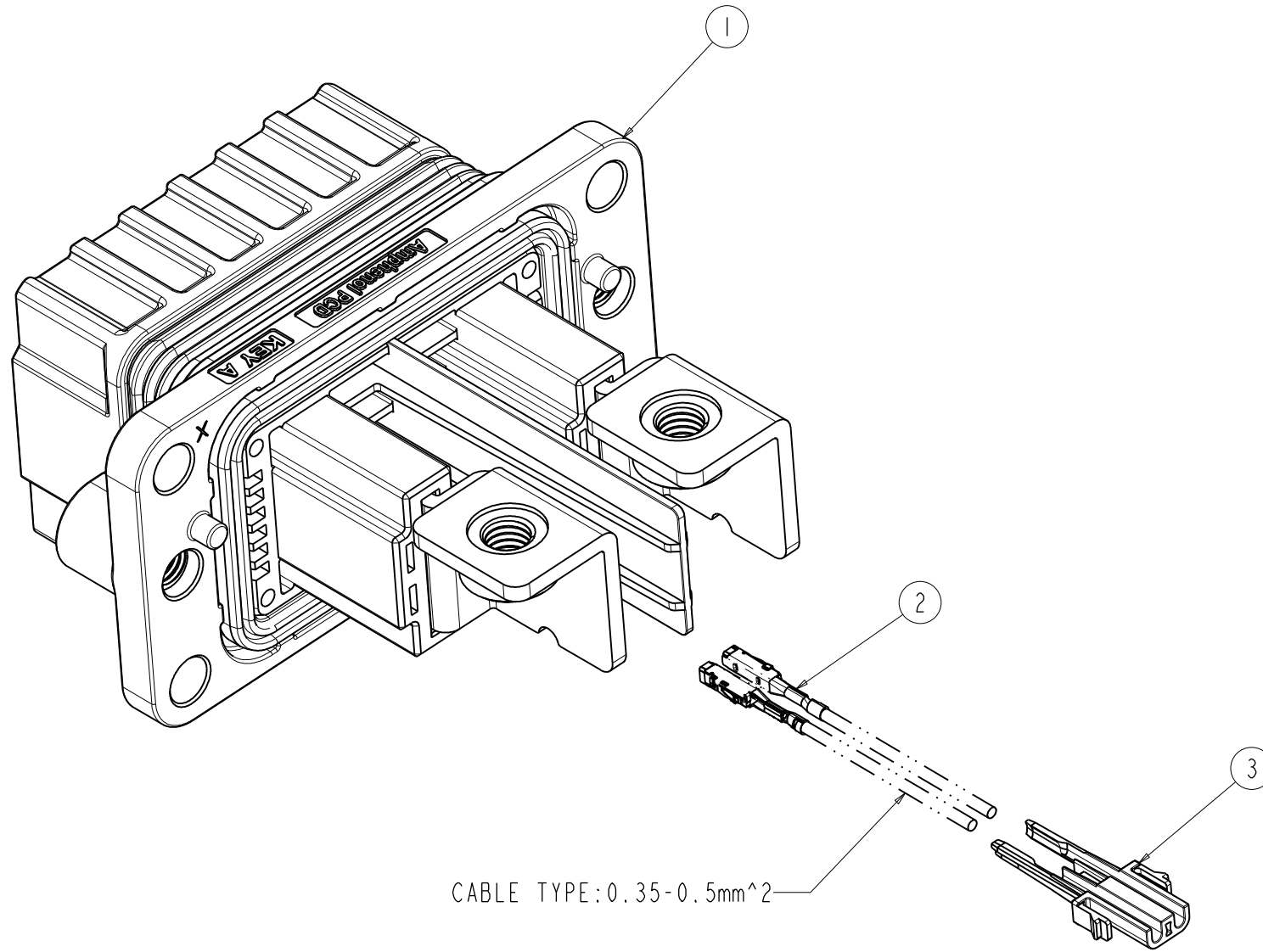

C-HVPC18022XXXXS01

C-HVPC18022XXXXS01

3	P01BP00469	TPA	1	loosen packing
2	C310003614S	Signal contact Separately order	2	
1	HVPC18022XH6	Receptacle body X=(A,B,C)	1	
Index	PN	Description	QTY	Note

SIZE	DWG NO.	REV
A3	C-HVPC18022XXXXS01	1
SCALE: 1:1		SHEET 2 OF 4

C-HVPC18022XXXXS01

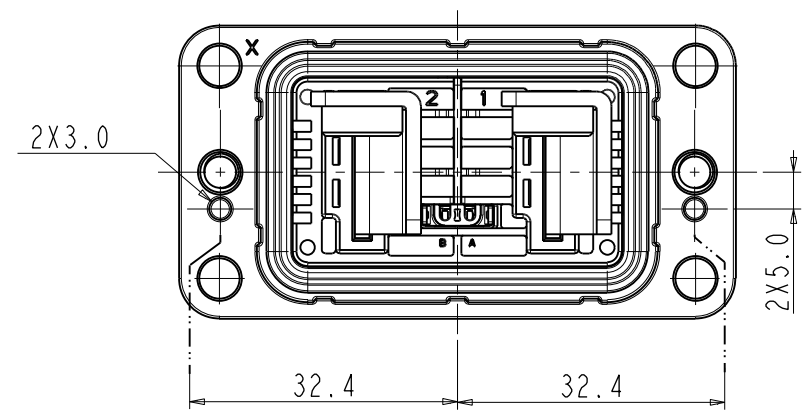
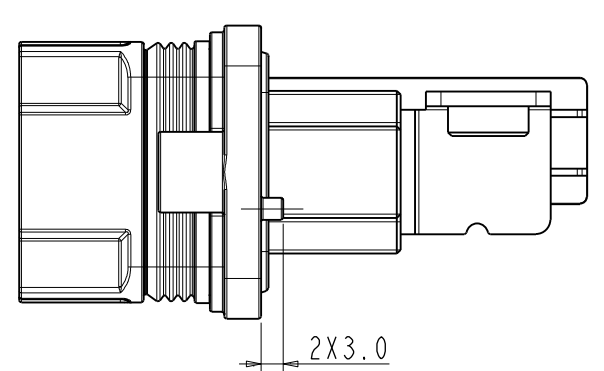
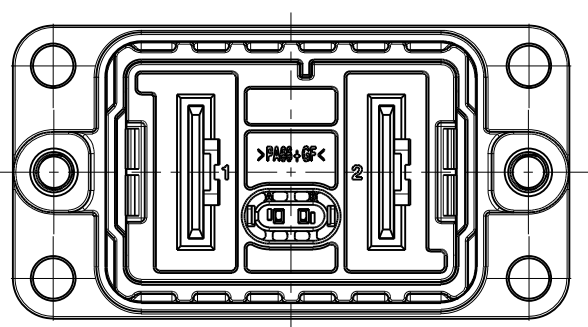
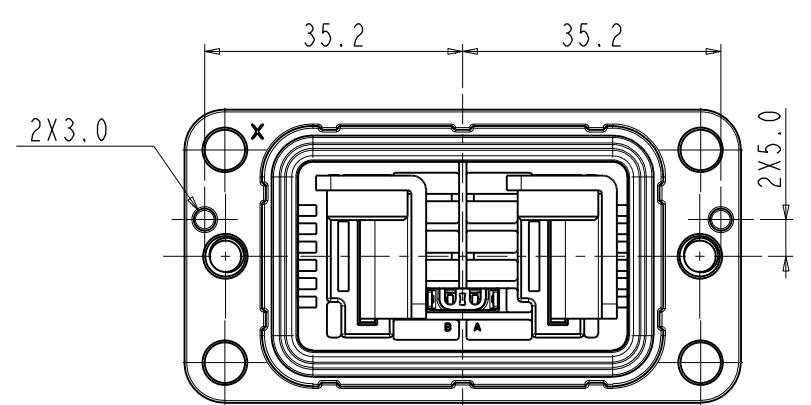
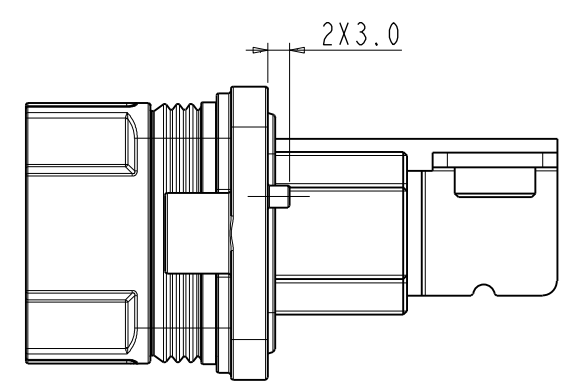
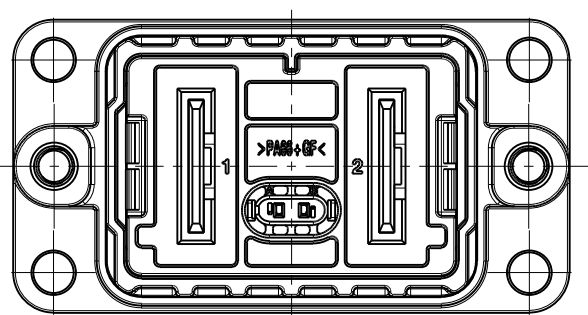
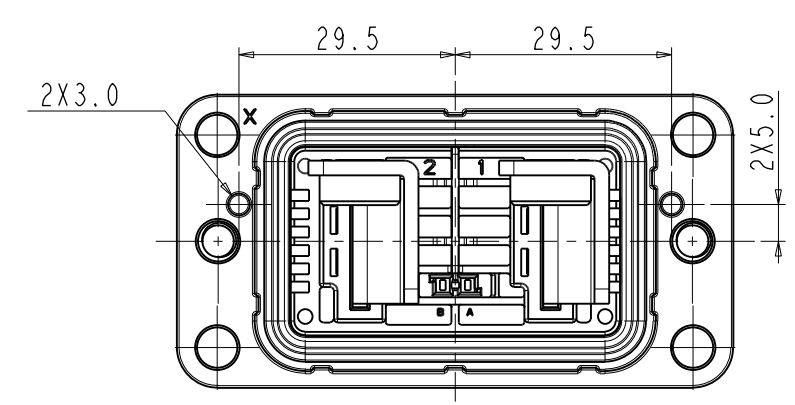
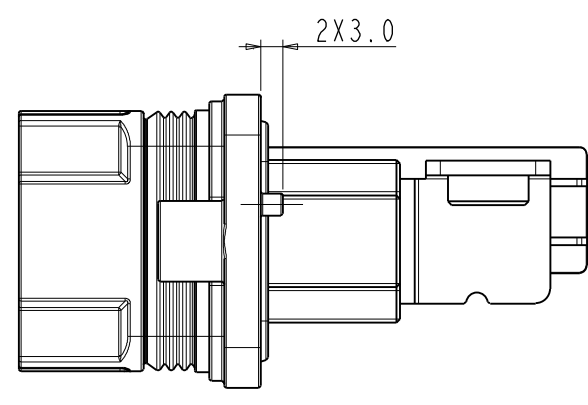
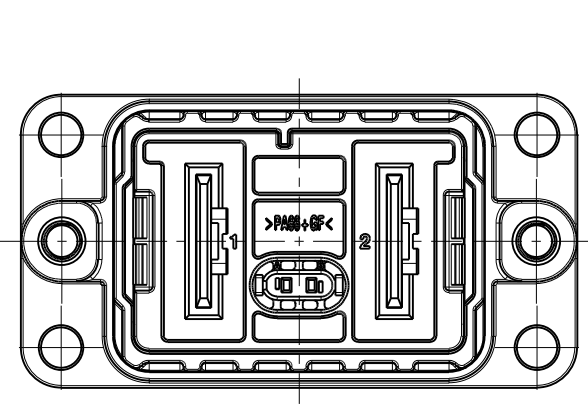

C-HVPC18022XXXXS01

C-HVPC18022XXXXS01

SIZE	DWG NO.	REV
A3	C-HVPC18022XXXXS01	1
SCALE: 1:1		SHEET 3 OF 4

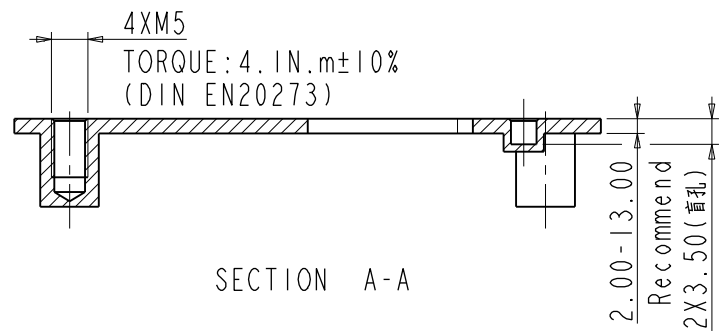
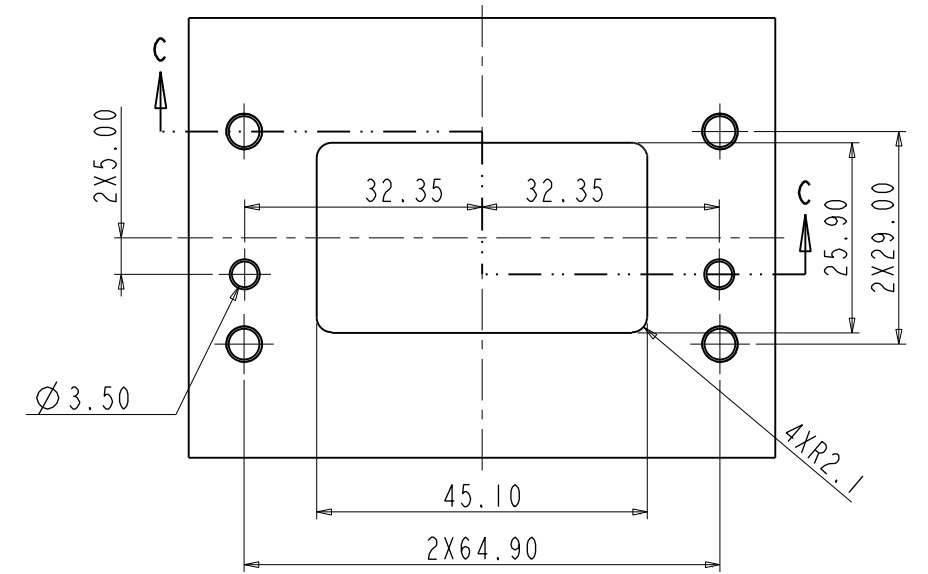
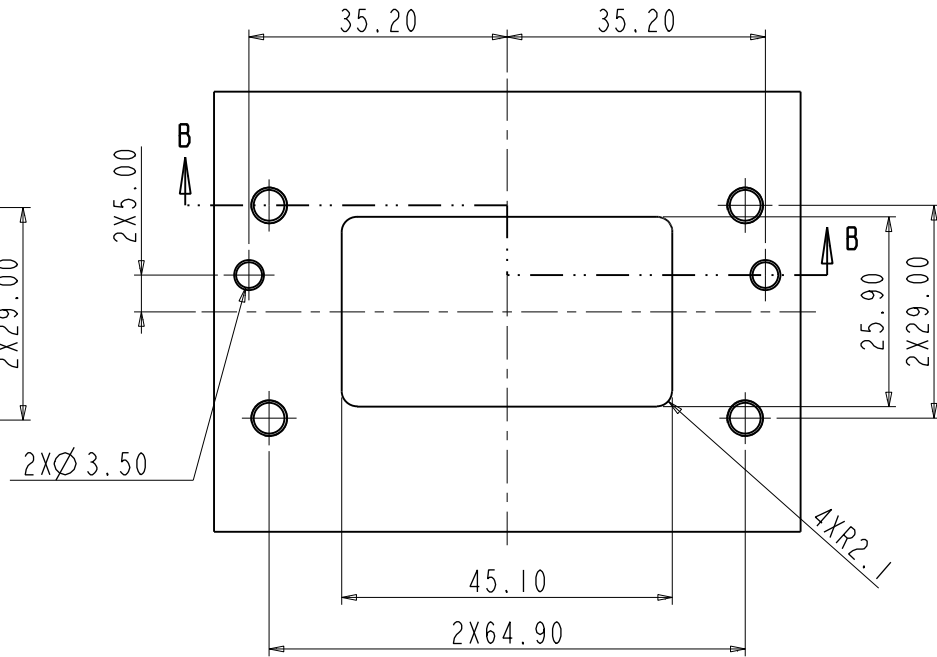
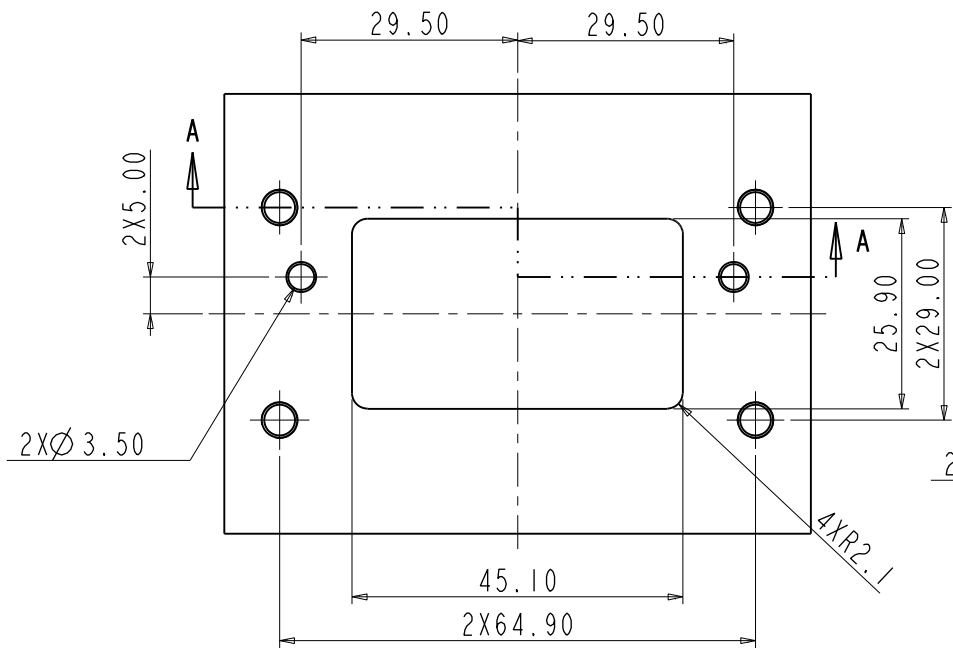

SECTION A-A

A KEY MOUNTING PLATE

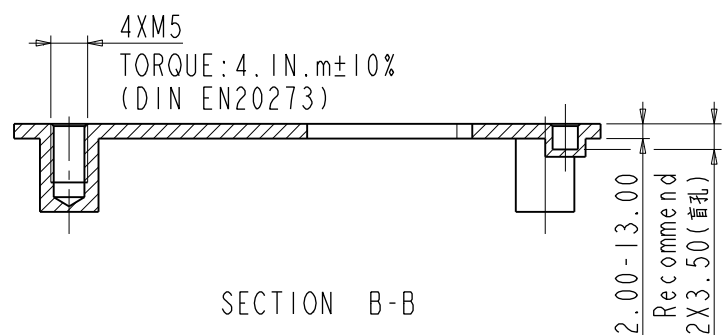

SECTION B-B

B KEY MOUNTING PLATE

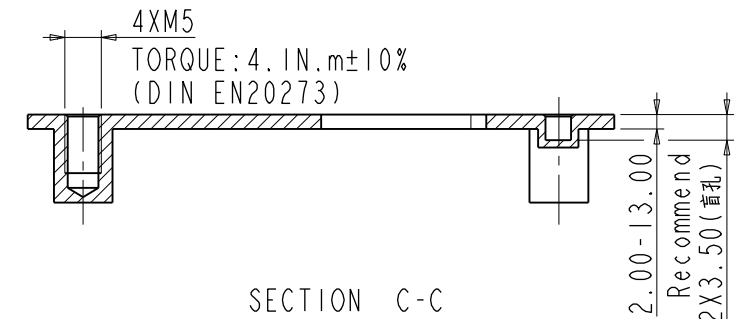

SECTION C-C

C KEY MOUNTING PLATE

C-HVPC18022XXXXS01

C-HVPC18022XXXXS01

SIZE	DWG NO.	REV
A3	C-HVPC18022XXXXS01	1
SCALE: 1:1		SHEET 4 OF 4