

Amphenol PCDSZ
ORIGINAL
PDF Format
R&D

REV	ECN	DESCRIPTION	DATE	MODIFIED
C	C3005	ADD CODING C	2018.10.22	
D	R3409-N	SIZE CHANGE OF STERN COVER	2019.08.14	
E	R4010W	ADJUST THE DATA/CORRECT THE ERROR	2019.12.25	

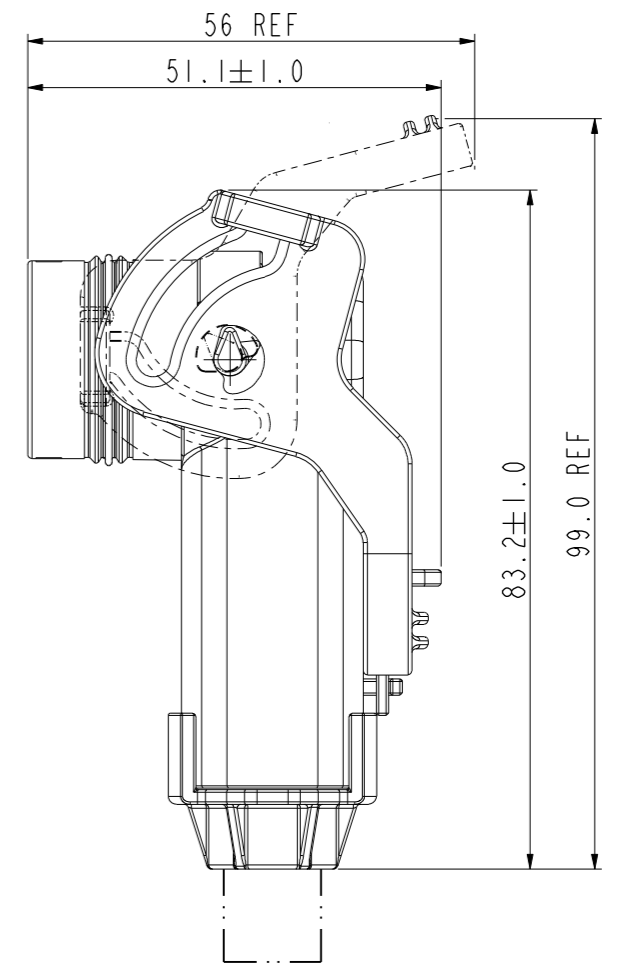
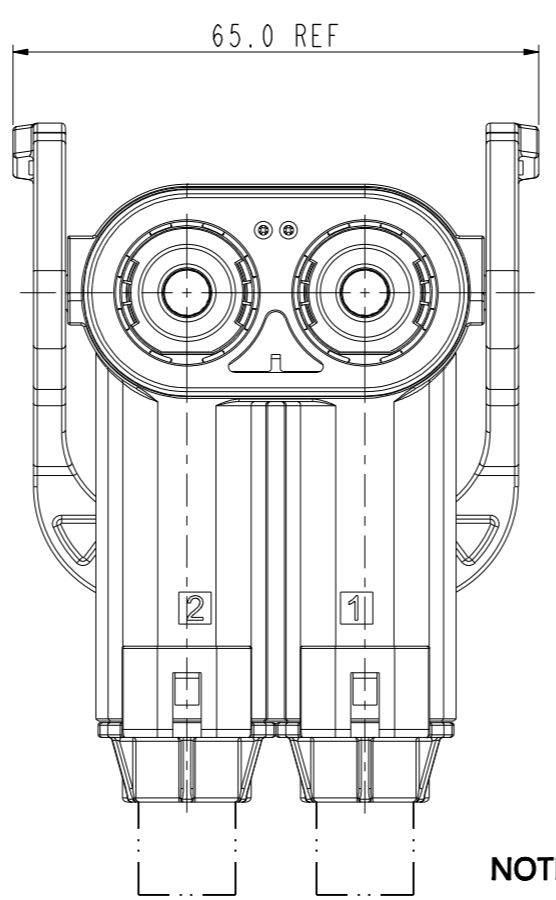
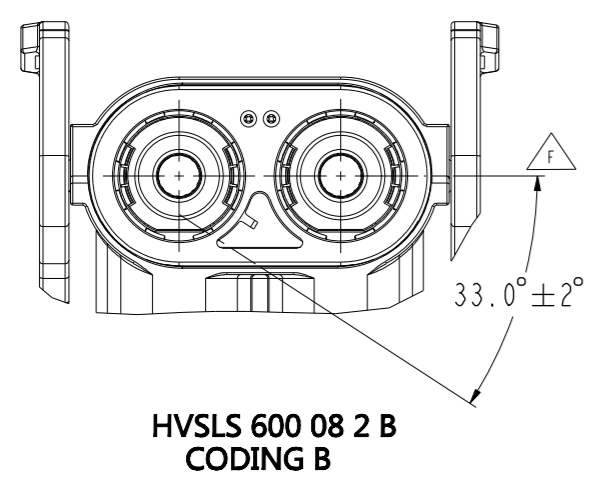
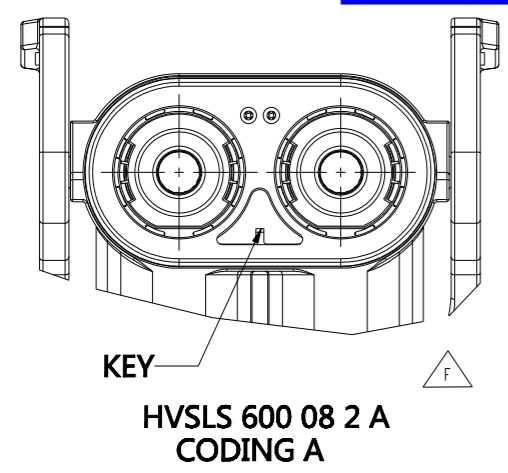

C-HVSL5600082XXXX

C-HVSL5600082XXXX

TECHNICAL DATA

CURRENT RATE (25MM ² CABLE)	120A @ AMBIENT 70°C	+
CURRENT RATE (16MM ² CABLE)	80A @ AMBIENT 70°C	+
RATING VOLTAGE (OVERVOLTAGE CATEGORY II POLLUTION DEGREE 2)	1000V DC	+
DIELECTRIC WITHSTANDING VOLTAGE	3000V AC(RMS)	+
INSULATION RESISTANCE	100MΩ MIN.@25°C	+
DURABILITY	50 CYCLES	⊙
SHIELDING	YES	
WATERPROOF (MATED CONDITION)	IP67、IP6K9K	+
PROTECTION LEVEL(UNMATED)	IP2XB	+
OPERATING TEMPERATURE	-40~125°C	
AMBIENT TEMPERATURE	-40~70°C	
RoHS	YES	+

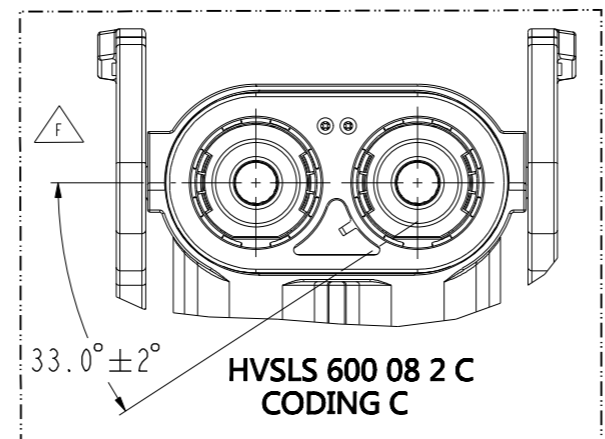

NOTES:

- MATERIAL & FINISH:
 △ F PLASTIC BODY: ZINC ALLOY COLOR ZINC PLATED
 POWER CONTACT: COPPER ALLOY SILVER PLATED
 HVIL CONTACTS: COPPER ALLOY GOLD PLATED
 SEAL RING: SI
- PART NUMBER DESCRIPTION:

HVLS 600 08 2 X X XX

A: CODING A
B: CODING B
C: CODING C

0: WITHOUT HVIL
1: WITH HVIL

25: CROSS-SECTION 25mm²
SHIELDING WIRE OD=11.9 ± 0.3mm

16: CROSS-SECTION 16mm²
SHIELDING WIRE OD=11.2 ± 0.25mm

DIMENSIONS	TOLERANCES	PROJECTION	TITLE		
ANSI Y14.5M UNITS: MM Pro/E FILE	.X ±0.5 .XX ±0.05 ANGLES ±0.5°		Amphenol Pcd Shenzhen		
ORIGINAL	THIS DOCUMENT CONTAINS PROPRIETARY INFORMATION WHICH IS THE CONFIDENTIAL PROPERTY OF AMPHENOL PCD SHENZHEN		ENGR	24/02/16	
			CHKD		
			APPD		
			SIZE	DWG NO.	REV
			A3	C-HVSL5600082XXXX	E
			CODE: 58982	SCALE: 1:1	SHEET 1 OF 2

+: CRITICAL CHARACTERISTICS/关键特性
⊙: IMPORTANT CHARACTERISTICS/重要特性

HVSL5600082X1XX (WITH HVIL)	7	C2200036952	16mm2	END CAP (WIRE OD=11.2 ± 0.25mm)	2
		C2200036951	25mm2	END CAP (WIRE OD=11.9 ± 0.3mm)	2
	6	C2700036492	16mm2	CABLE SEAL (WIRE OD=11.2 ± 0.25mm)	2
		C2700036491	25mm2	CABLE SEAL (WIRE OD=11.9 ± 0.3mm)	2
	5	C310005004	N/A	SPRING	2
	4	C2000036511	16mm2	PIN CONTACT	2
		C200003651	25mm2	PIN CONTACT	2
	3	SEE TABLE 1	N/A	MAIN BODY & WITH HVIL	1
	2	C420003648	N/A	SOCKET CONTACT BODY	2
1	C220003697	N/A	SOCKET CONTACT GAP	2	
ASSEMBLY P/N	ITEM	COMPONENT P/N	CABLE SIZE	DESCRIPTION	Q'TY

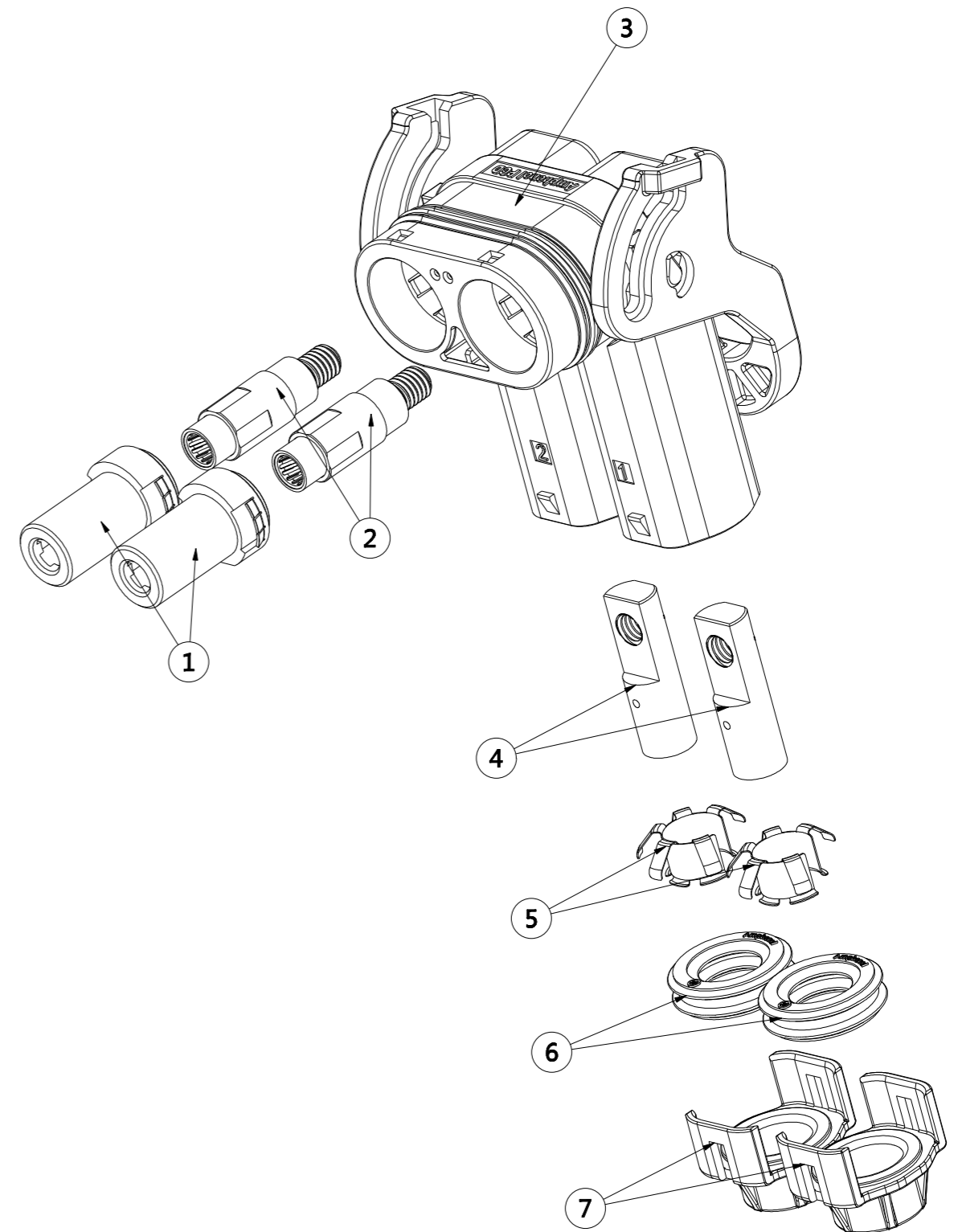

TABLE 1
HVSL5600082X1 SELECTION:

MAIN BODY P/N	KEY X
HVSL5600082A1	KEY A
HVSL5600082B1	KEY B
HVSL5600082C1	KEY C

TABLE 2
HVSL5600082X0 SELECTION:

MAIN BODY P/N	KEY X
HVSL5600082A0	KEY A
HVSL5600082B0	KEY B
HVSL5600082C0	KEY C

HVSL5600082X0XX (WITHOUT HVIL)	7	C2200036952	16mm2	END CAP (WIRE OD=11.2 ± 0.25mm)	2
		C2200036951	25mm2	END CAP (WIRE OD=11.9 ± 0.3mm)	2
	6	C2700036492	16mm2	CABLE SEAL (WIRE OD=11.2 ± 0.25mm)	2
		C2700036491	25mm2	CABLE SEAL (WIRE OD=11.9 ± 0.3mm)	2
	5	C310005004	N/A	SPRING	2
	4	C2000036511	16mm2	PIN CONTACT	2
		C200003651	25mm2	PIN CONTACT	2
	3	SEE TABLE 2	N/A	MAIN BODY & WITHOUT HVIL	1
	2	C420003648	N/A	SOCKET CONTACT BODY	2
1	C220003697	N/A	SOCKET CONTACT GAP	2	
ASSEMBLY P/N	ITEM	COMPONENT P/N	CABLE SIZE	DESCRIPTION	Q'TY