

Amphenol PCD SZ
ORIGINAL
PDF Format
R&D

REV	ECN	DESCRIPTION	DATE	MODIFIED
C		UPDATE	2016.06.07	
D	R5155W	UPDATED DRAWING	2021.02.19	

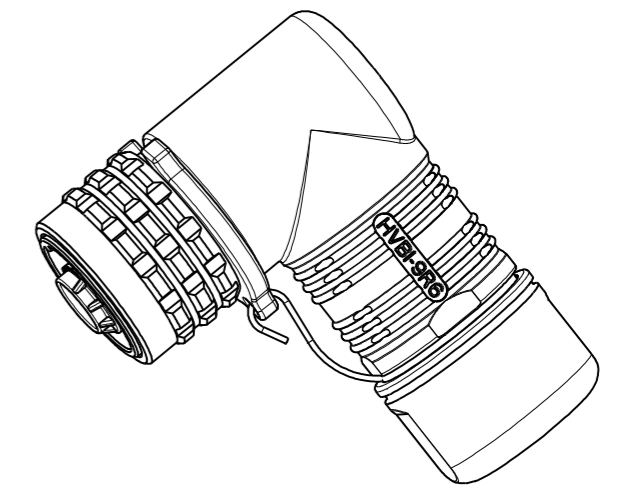
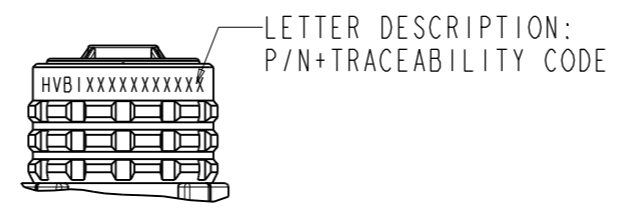
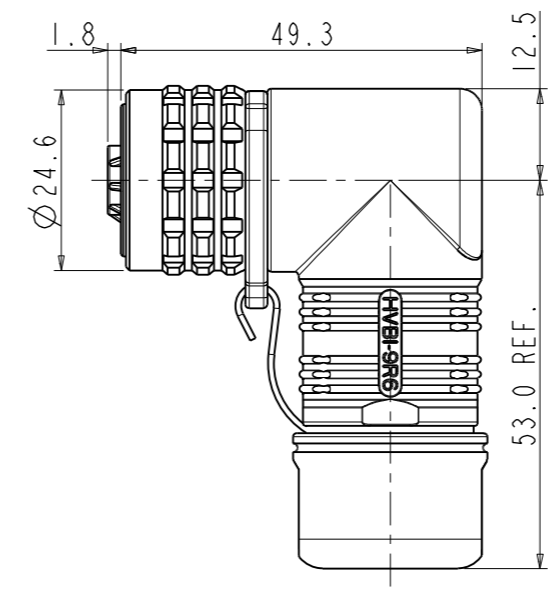
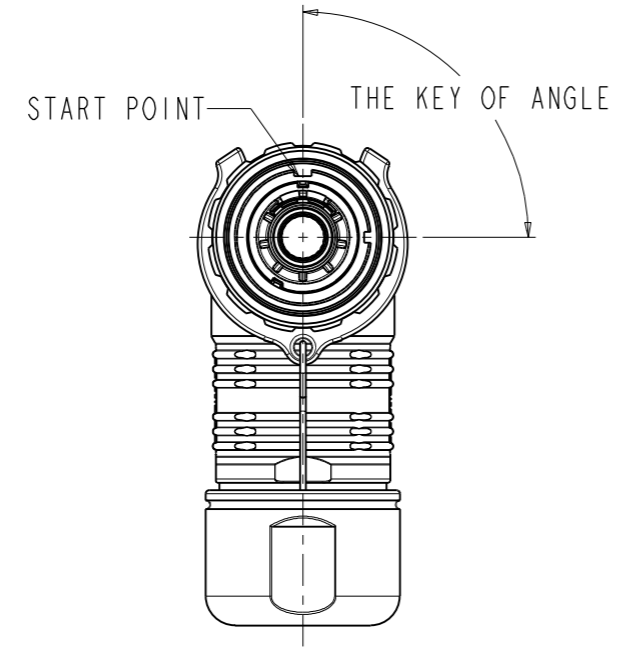

C-HVBI902R6XFCXXXFGXXL0000

C-HVBI902R6XFCXXXFGXXL0000

TECHNICAL DATA		
CURRENT RATE (25MM ² SHIELD CABLE)	120A @ AMBIENT 70°C	+
CURRENT RATE (20MM ² SHIELD CABLE)	100A @ AMBIENT 70°C	+
CURRENT RATE (16MM ² SHIELD CABLE)	80A @ AMBIENT 70°C	+
CURRENT RATE (0.5MM ² CABLE)	5A @ AMBIENT 70°C	+
RATING VOLTAGE (OVERVOLTAGE CATEGORY II POLLUTION DEGREE 2)	1000V DC	+
OPERATING TEMPERATURE	-40~125°C	
DIELECTRIC WITH STANDING VOLTAGE	POWER CONTACT 3000V AC(RMS)	+
	HVIL CONTACT 660V AC(RMS)	
INSULATION RESISTANCE	200MΩ MIN. 25°C, NO CABLE	+
DURABILITY	50 CYCLES	⊙
SHIELDING	YES	
WATERPROOF (MATED CONDITION)	IP 67, IP6K9K	+
PROTECTION LEVEL	IP2XB	+
AMBIENT TEMPERATURE	-40~70°C	
RoHS COMPLIANCE	YES	+

DIMENSIONS	TOLERANCES	PROJECTION	Amphenol PCD Shenzhen	
ANSI Y14.5M	.X ±0.5		ENGR	2016.06.07
UNITS: MM	.XX ±0.05		CHKD	
Pro/E FILE	ANGLES ±2°		APPD	
ORIGINAL	THIS DOCUMENT CONTAINS PROPRIETARY INFORMATION WHICH IS THE CONFIDENTIAL PROPERTY OF Amphenol PCD Shenzhen Co. Ltd Amphenol PCD Shenzhen Co. Ltd RESERVES THE RIGHT TO CLARIFY THIS DRAWING		SIZE	DWG NO.
			A3	C-HVBI902R6XFCXXXFGXXL0000

TITLE		
HVBI-9R6 PLUG		
SIZE	DWG NO.	REV
A3	C-HVBI902R6XFCXXXFGXXL0000	D
CODE: 58982	SCALE: 1:1	SHEET 1 OF 2

"+" CRITICAL CHARACTERISTICS
"⊙" IMPORTANT CHARACTERISTICS

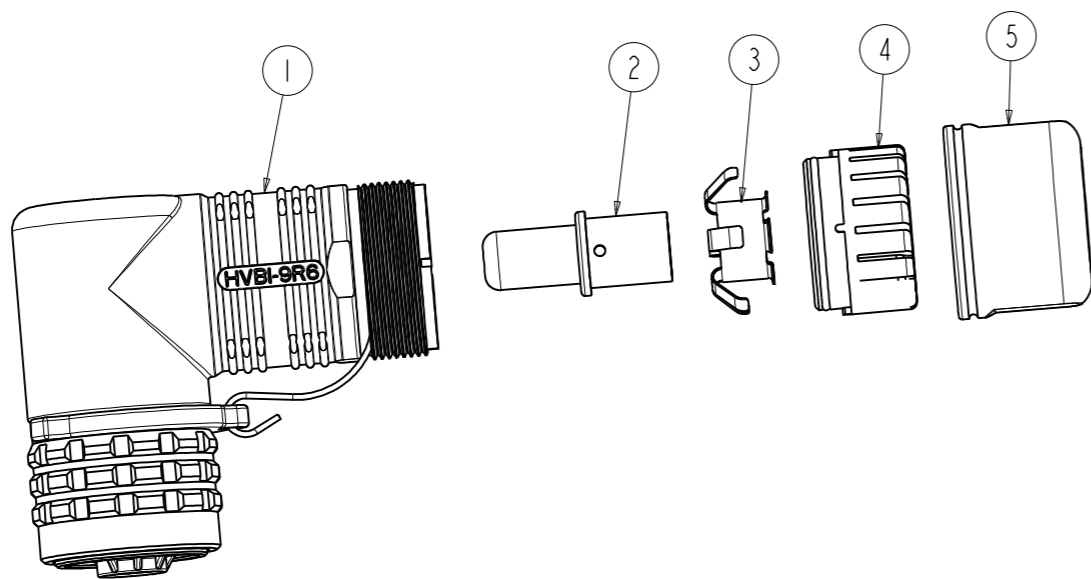

HOW TO ORDER:
HVBI902R6-XFC-XXX-FG-XX-L0000 

HVIL CODE:
A: WITH HVIL
B: WITHOUT HVIL

ANGLE AND COLOR:
ARD: 30°, RED
BBK: 60°, BLACK
CYL: 90°, YELLOW
DGR: 120°, GREEN
EBL: 150°, BLUE
FPU: 180°, PURPLE

CABLE OD:
25: 25MM^2 SHIELD CABLE (OD: 11.5~13.0MM)
20: 20MM^2 SHIELD CABLE (OD: 11.0~12.0MM)
16: 16MM^2 SHIELD CABLE (OD: 10.9~12.0MM)

HVBI902R6XFCXXXFGXXL0000	5	C200005083	1
	4	SEE TABLE I	1
	3	C310005004	1
	2	SEE TABLE I	1
	1	HVBI902R6XFCXXX	1
ASSEMBLY P/N	ITEM	COMPONENT P/N	Q'TY

TABLE I

CODE	DESCRIPTION	2# PART	4# PART
25	25MM^2 SHIELD CABLE	C200005087	C427005063
20	20MM^2 SHIELD CABLE	C200005087	C427005063
16	16MM^2 SHIELD CABLE	C2000050871	C4270050631

C-HVBI902R6XFCXXXFGXXL0000

C-HVBI902R6XFCXXXFGXXL0000