

REV	ECN	DESCRIPTION	DATE	MODIFIED
6	R3242N	ADD KEY B AND UPDATE TECHNICAL DATA	2019.04.23	

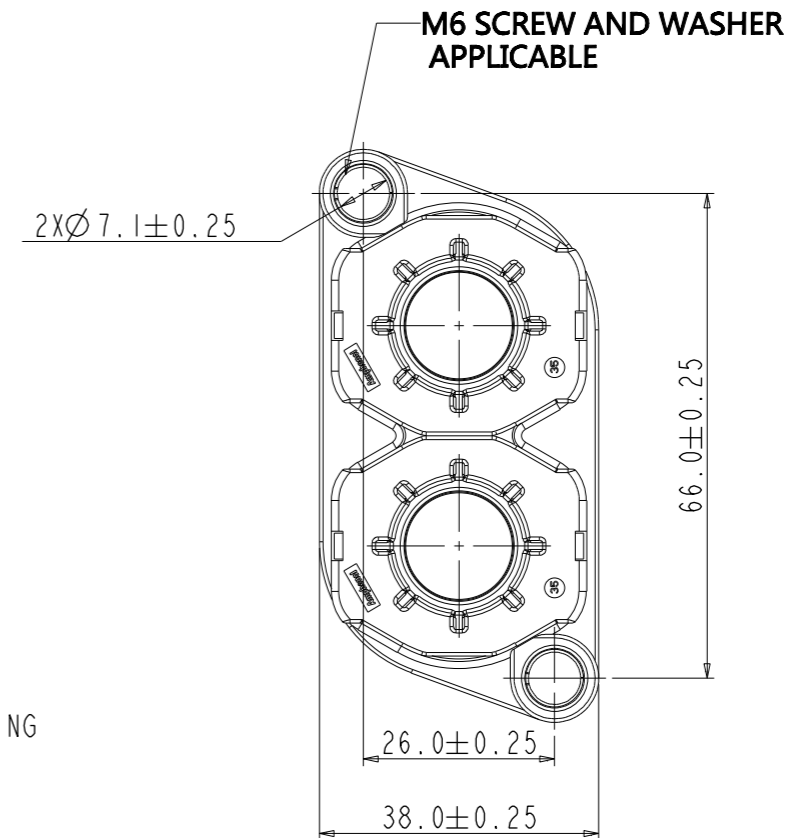
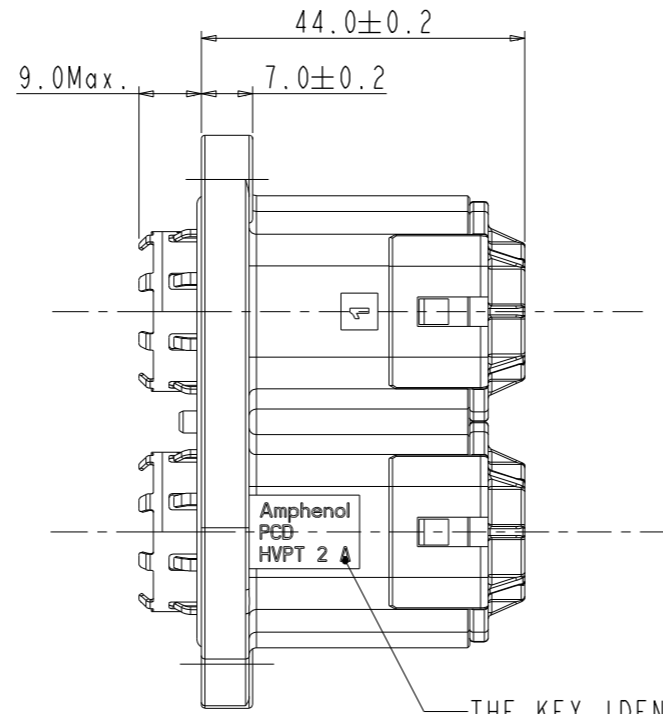
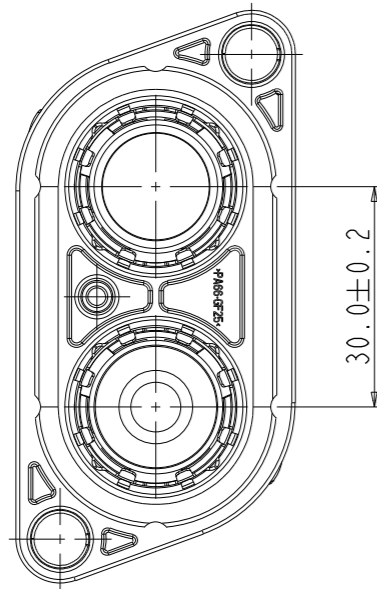
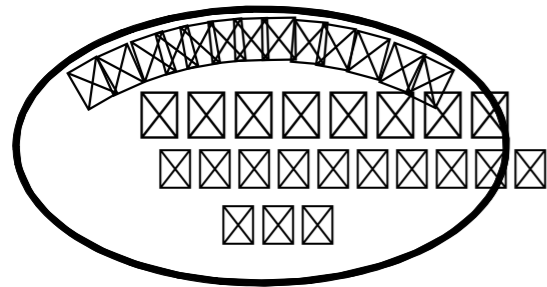

C-HVPT2XXX

安费诺精密连接器(深圳)有限公司
Amphenol PCD Shenzhen
受控文件
2019年5月28日

C-HVPT2XXX

HVPT 2 X XX
A: KEY A
B: KEY B
25: FOR 25mm² Shielded WIRE;OD=11.9±0.4mm
35: FOR 35mm² Shielded WIRE;OD=14.2±0.4mm
50: FOR 50mm² Shielded WIRE;OD=16.5±0.4mm
70: FOR 70mm² Shielded WIRE;OD=19.0±0.4mm

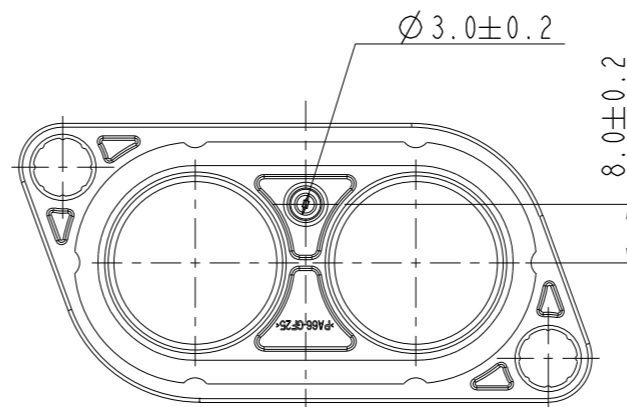

KEY A:HVPT2A

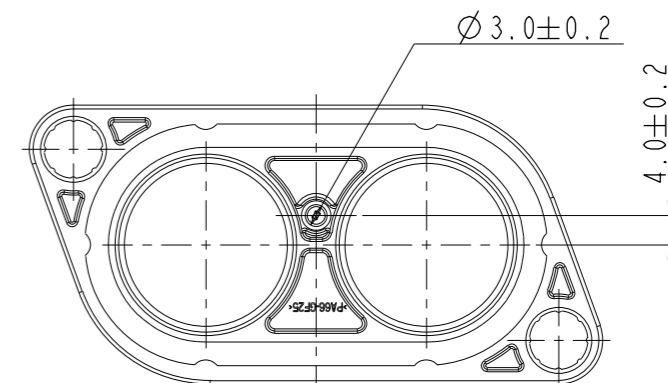

KEY B:HVPT2B

TECHNICAL DATA	
OPERATING TEMPERATURE	-40 ~ 125 °C
SHIELDING	YES
WATERPROOF(MATED CONDITION)	IP67&IP69K
AMBIENT TEMPERATURE	-40 ~ 70 °C

DIMENSIONS	TOLERANCES	PROJECTION	TITLE		
ANSI Y14.5M UNITS: MM Pro/E FILE	.X ±0.5 .XX ±0.05 ANGLES ±0.5°		HVPT 2X PASS-THRU CABLE SEAL GLAND		
ORIGINAL	THIS DOCUMENT CONTAINS PROPRIETARY INFORMATION WHICH IS THE CONFIDENTIAL PROPERTY OF AMPHENOL PCD SHENZHEN	ENGR Apr-08-16			
			APPD	CODE: 58982	SCALE: 1:1

KEY A

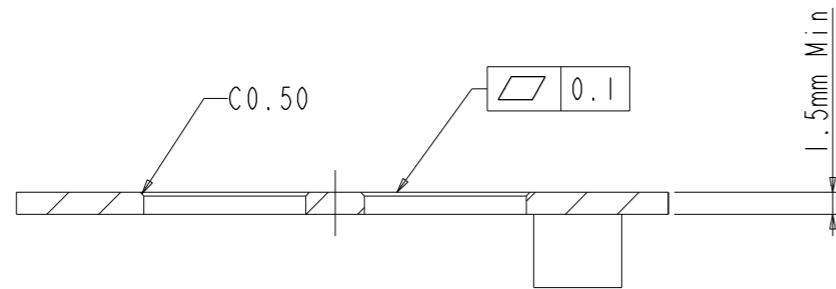
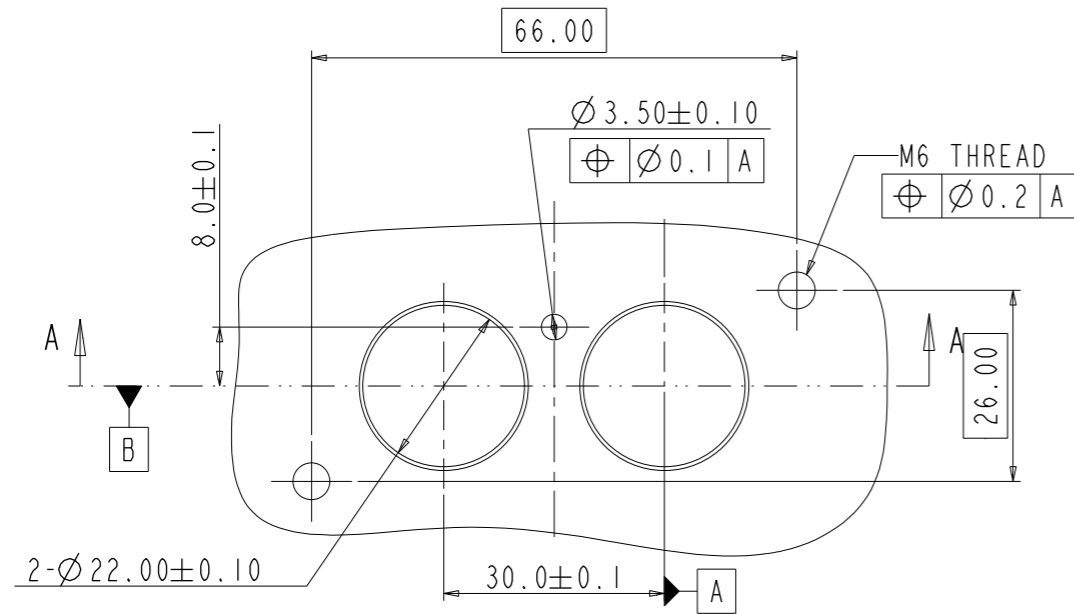

SECTION A-A

PANNEL DRAWING

安费诺精密连接器(深圳)有限公司
Amphenol PCD Shenzhen

受控文件

2019年5月28日

KEY B

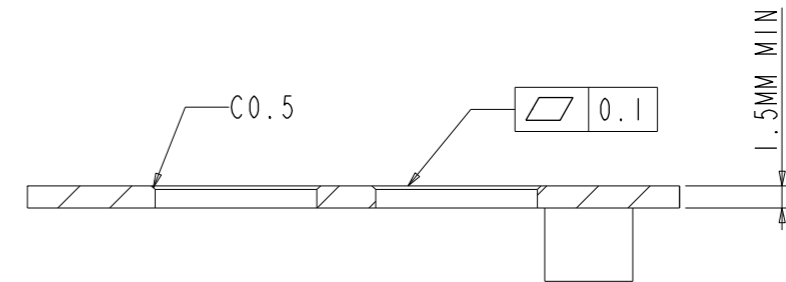
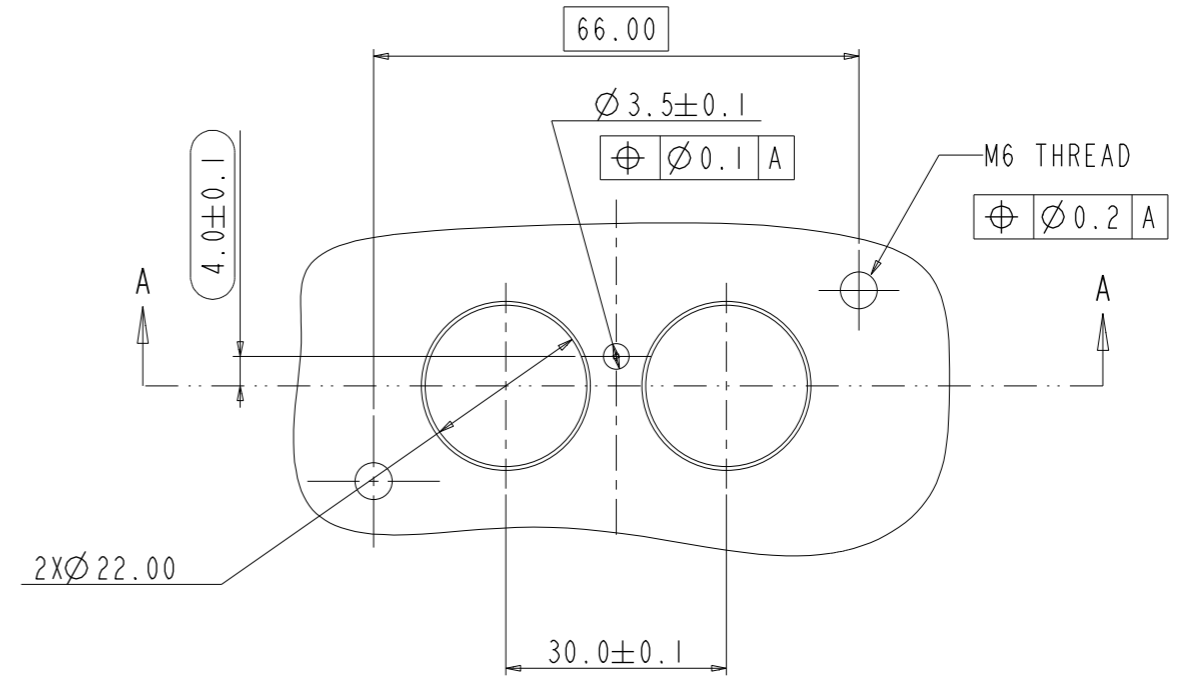

SECTION A-A

PANNEL DRAWING

SIZE A3	DWG NO. C-HVPT2XXX	REV 6
CODE: 58982	SCALE: 1:1	SHEET 2 OF 3

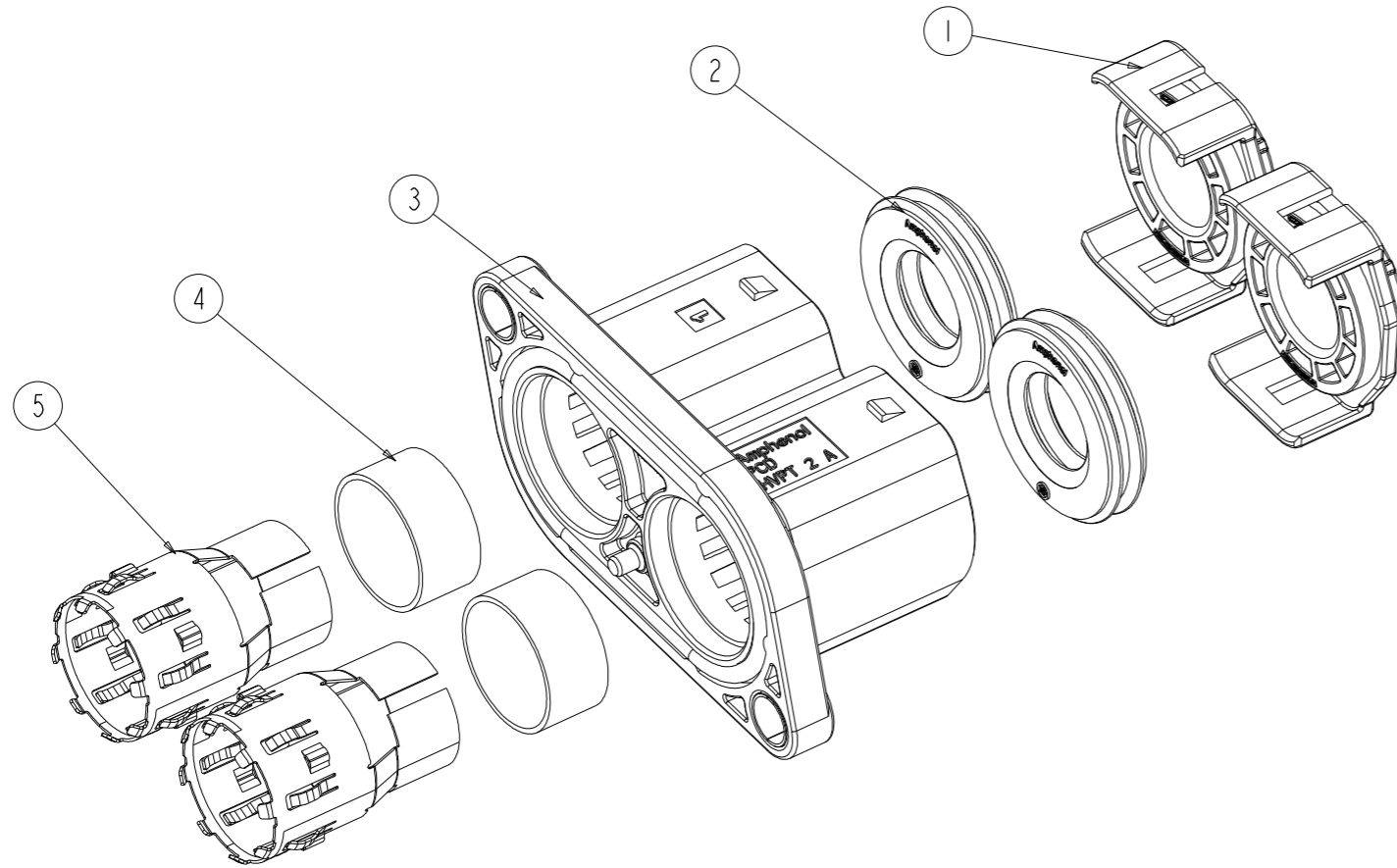

HVPT2A25	5	C310003642	2	SHIELDING
	4	C2000036633	2	OUT FERRULE
	3	HVPT2A	1	HOUSING
	2	C2700036043	2	CABLE SEAL
	1	C2200037253	2	BACK CAP
ITEM	P/N	QTY	DESCRIPTION	

HVPT2B25	5	C310003642	2	SHIELDING
	4	C2000036633	2	OUT FERRULE
	3	HVPT2B	1	HOUSING
	2	C2700036043	2	CABLE SEAL
	1	C2200037253	2	BACK CAP
ITEM	P/N	QTY	DESCRIPTION	

HVPT2A35	5	C310003643	2	SHIELDING
	4	C2000036632	2	OUT FERRULE
	3	HVPT2A	1	HOUSING
	2	C2700036042	2	CABLE SEAL
	1	C2200037252	2	BACK CAP
ITEM	P/N	QTY	DESCRIPTION	

HVPT2B35	5	C310003643	2	SHIELDING
	4	C2000036632	2	OUT FERRULE
	3	HVPT2B	1	HOUSING
	2	C2700036042	2	CABLE SEAL
	1	C2200037252	2	BACK CAP
ITEM	P/N	QTY	DESCRIPTION	

HVPT2A50	5	C310003644	2	SHIELDING
	4	C2000036631	2	OUT FERRULE
	3	HVPT2A	1	HOUSING
	2	C2700036041	2	CABLE SEAL
	1	C2200037251	2	BACK CAP
ITEM	P/N	QTY	DESCRIPTION	

HVPT2B50	5	C310003644	2	SHIELDING
	4	C2000036631	2	OUT FERRULE
	3	HVPT2B	1	HOUSING
	2	C2700036044	2	CABLE SEAL
	1	C2200037251	2	BACK CAP
ITEM	P/N	QTY	DESCRIPTION	

HVPT2A70	5	C310003645	2	SHIELDING
	4	C2000036630	2	OUT FERRULE
	3	HVPT2A	1	HOUSING
	2	C2700036044	2	CABLE SEAL
	1	C2200037254	2	BACK CAP
ITEM	P/N	QTY	DESCRIPTION	

HVPT2B70	5	C310003645	2	SHIELDING
	4	C2000036630	2	OUT FERRULE
	3	HVPT2B	1	HOUSING
	2	C2700036044	2	CABLE SEAL
	1	C2200037254	2	BACK CAP
ITEM	P/N	QTY	DESCRIPTION	

C-HVPT2XXX

C-HVPT2XXX

安费诺精密连接器(深圳)有限公司
Amphenol PCD Shenzhen

受控文件

2019年5月28日

SIZE	DWG NO.	REV
A3	C-HVPT2XXX	6
CODE: 58982	SCALE: 1:1	SHEET 3 OF 3