

Amphenol PCDSZ
ORIGINAL
PDF Format
R&D

REV	ECN	DESCRIPTION	DATE	MODIFIED
V0-4		ADD KEY POSITION	Mar-14-23	
V0-5		UPDATE DESIGN	Apr-26-23	
V0-6		ADD PE MARK	May-19-23	
A	C6896	RELEASE	Jun-30-23	

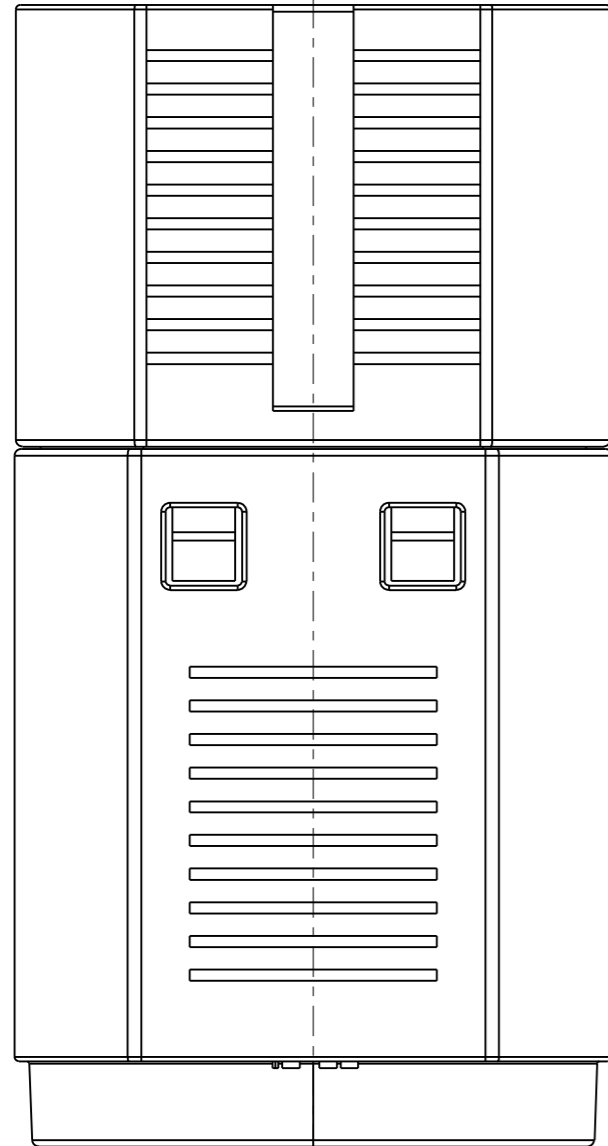
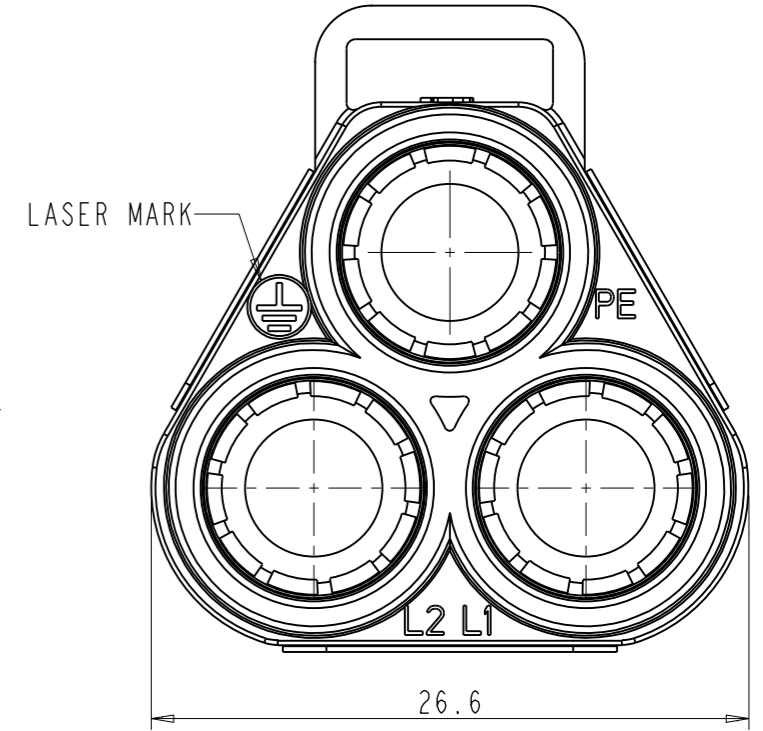
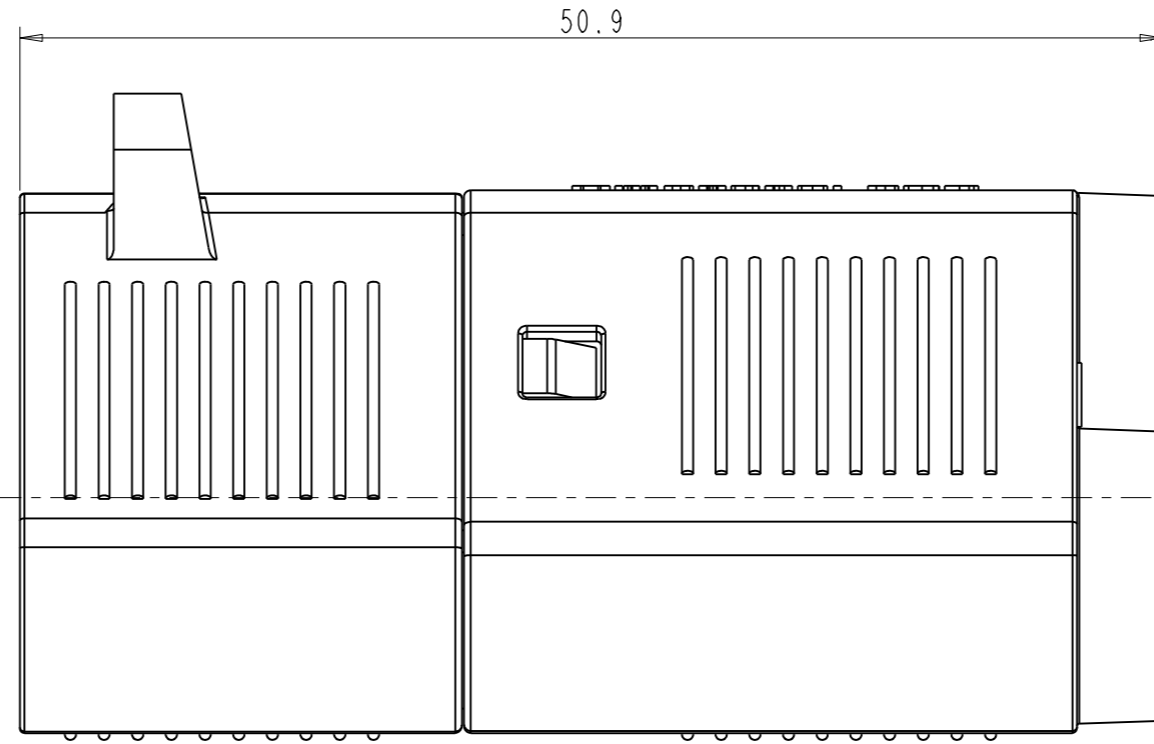
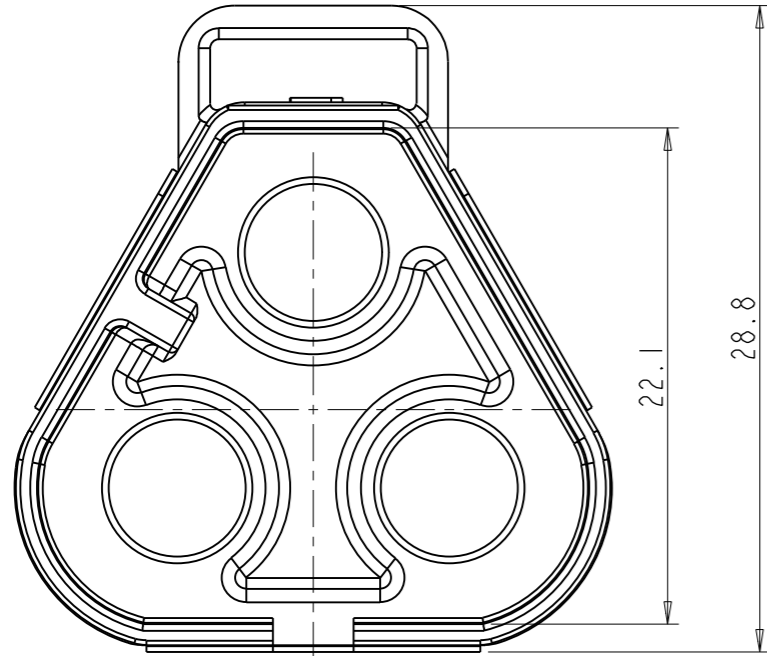

安费诺精密连接器(深圳)有限公司
Amphenol PCD Shenzhen
受控文件
2023年7月11日

NOTES

- MATERIALS:
HOUSING: PA UL94 V-0
CONTACT: COPPER (PLATING SLIVER)
- ELECTRICAL CHARACTERISTICS:
CURRENT RATING: 80A
VOLTAGE RATING: 300V
WITHSTAND VOLTAGE: 1500V/MIN
INSULATION RESISTANCE: 100MΩ
- OPERATING TEMPERATURE RANGE: -40°C TO +125°C
- WIRE RANGE: 6~8 AWG
- MATING CYCLES: 200 TIMES MAX
- RoHS COMPLIANCE.

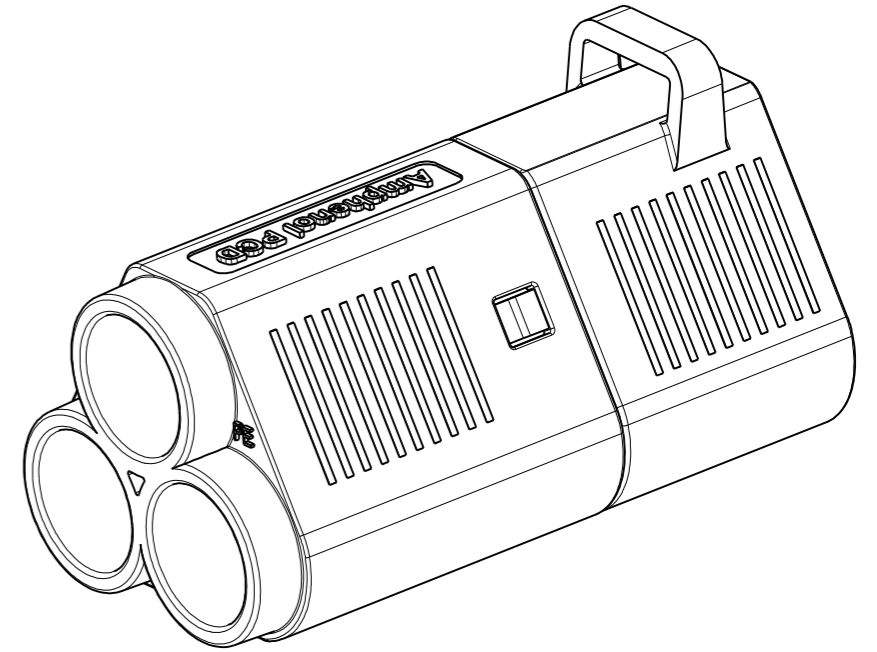

3D MODEL SHOWN

DIMENSIONS	TOLERANCES	PROJECTION	TITLE		
ANSI Y14.5M UNITS: MM Pro/E FILE	.X ±0.5 .XX ±0.05 ANGLES ±2°		SPC SERIES 3 POS WITH WIRE CONNECTOR		
ORIGINAL	THIS DOCUMENT CONTAINS PROPRIETARY INFORMATION WHICH IS THE CONFIDENTIAL PROPERTY OF Amphenol PCD Shenzhen Co. Ltd Amphenol PCD Shenzhen Co. Ltd RESERVES THE RIGHT TO CLARIFY THIS DRAWING	ENGR	SIZE	DWG NO.	REV
		CHKD APPD	A3	SPCM03206P_C	A
			SCALE: 1:1		SHEET 1 OF 2

SPCM03206P_C

SPCM03206P_C

ITEM NO	DESCRIPTION	QTY
1	OUTLET MIDDLE HOUSING	1
2	MALE CONTACT	3
3	OUTLET END COVER	1

NOTES:

- ITEM ② FEMALE CONTACT P/N: P01ES00031 NOT INCLUDED IN FINISHED PRODUCT SPCM03206P CONTACT SHOULD BE ORDERED SEPARATELY.
- ITEM ② : REEL PACKING. 1000PCS FOR ONE REEL

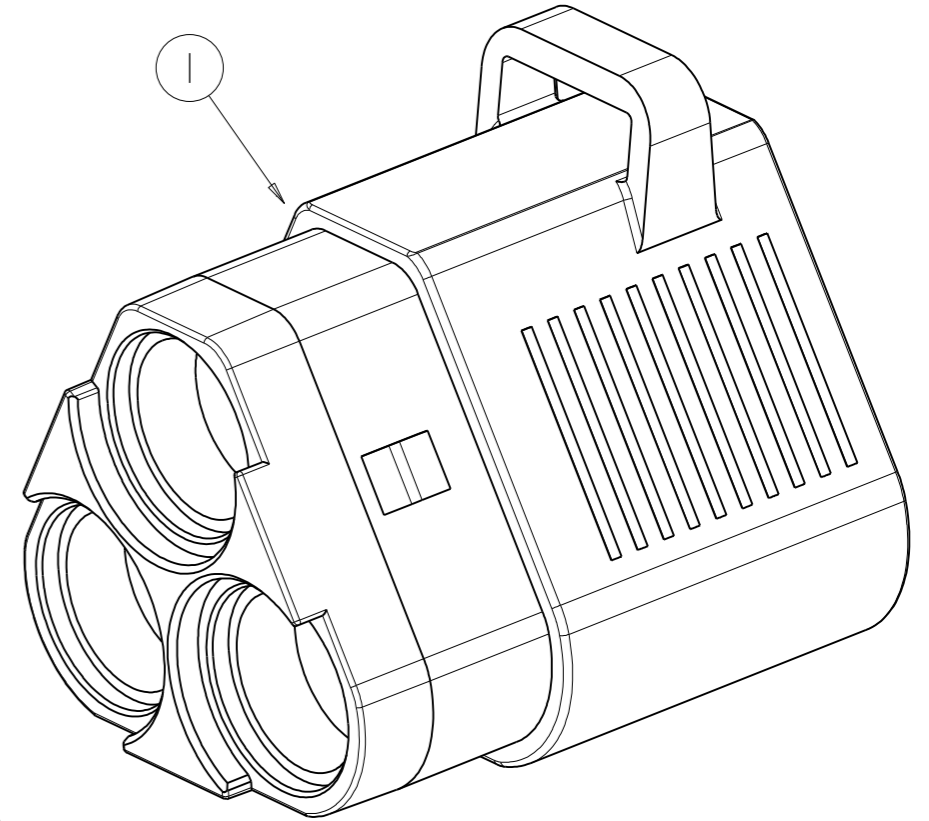
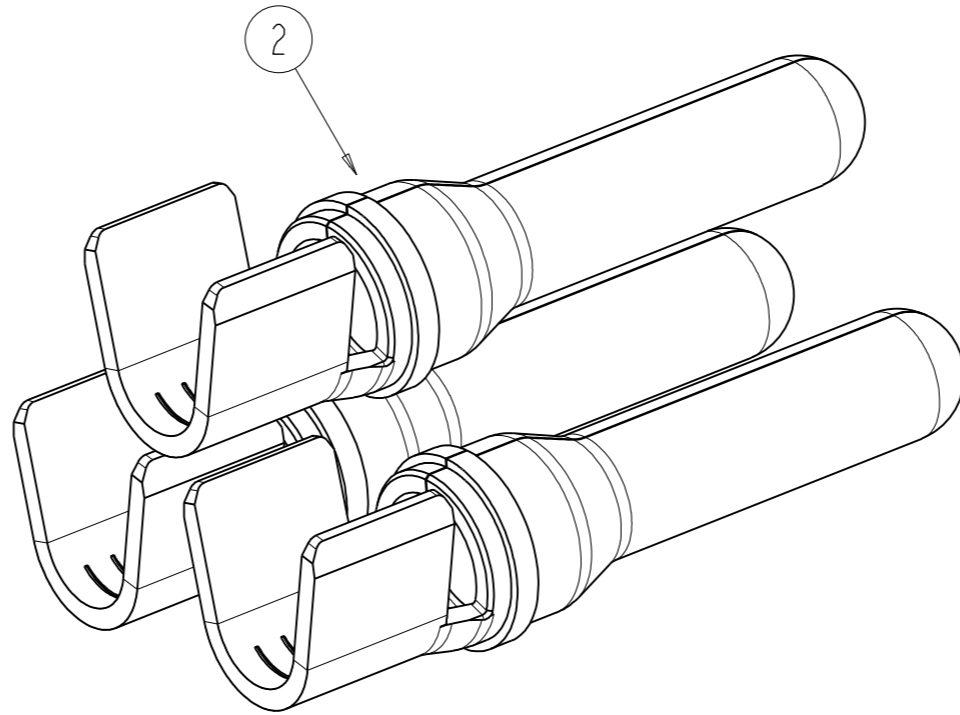
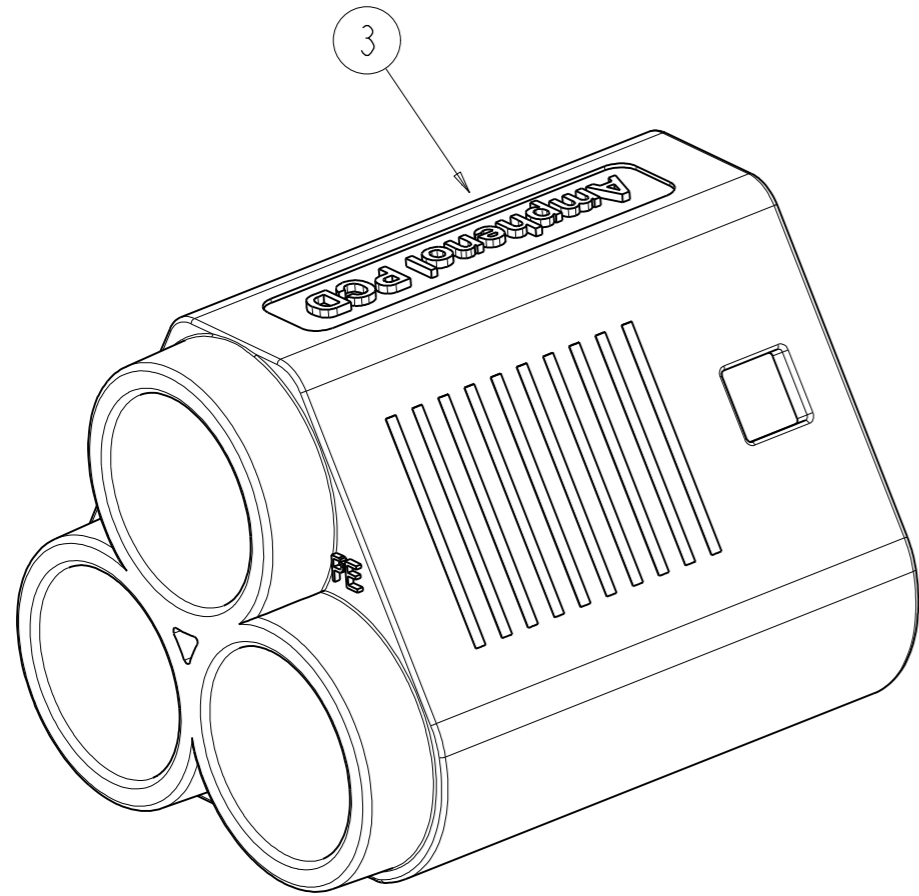

安费诺精密连接器(深圳)有限公司
Amphenol PCD Shenzhen
受控文件
2023年7月11日

SPCM03206P_C

SPCM03206P_C

SIZE	DWG NO.	REV
A3	SPCM03206P_C	A
SCALE: 1:1		SHEET 2 OF 2