

REV	ECN	DESCRIPTION	DATE	MODIFIED
1		PRE RELEASE	Apr-08-21	
2	R6045W	ADD RIBS OPTIMIZE STRUCTURE	Jul-12-22	..

Amphenol PCD
ORIGINAL
PDF Format
R&D

TORQUE FOR BUSBAR MOUNT: 5.3N.m±10%
TORQUE FOR FINGER POST: 0.2N.m
USE TIGHTEN GLUE, 使用螺纹紧固胶

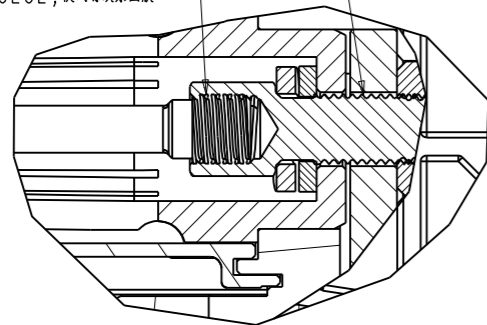

DETAIL A
SCALE 8:5

APPLICATION:
POLLUTION DEGREE 2 / 污染等级 2
OVERVOLTAGE CATEGORY II / 过电压类别 2
INHOMOGENEOUS FIELD / 非均匀电场
ALTITUDE NO MORE THAN 2000m / 海拔不高于2000m

+ CRITICAL CHARACTERISTICS 关键特性
◎ IMPORTANT CHARACTERISTICS 重要特性

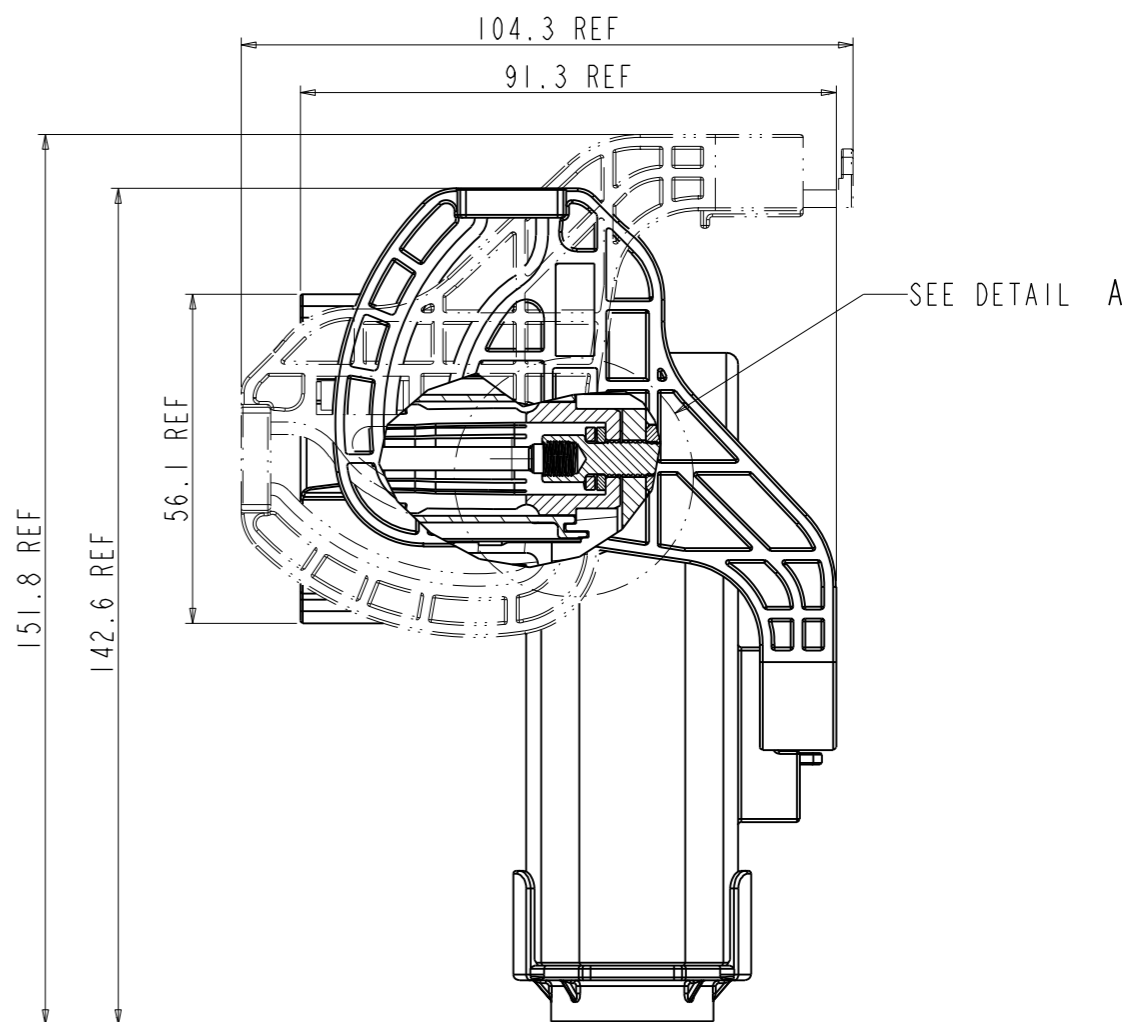
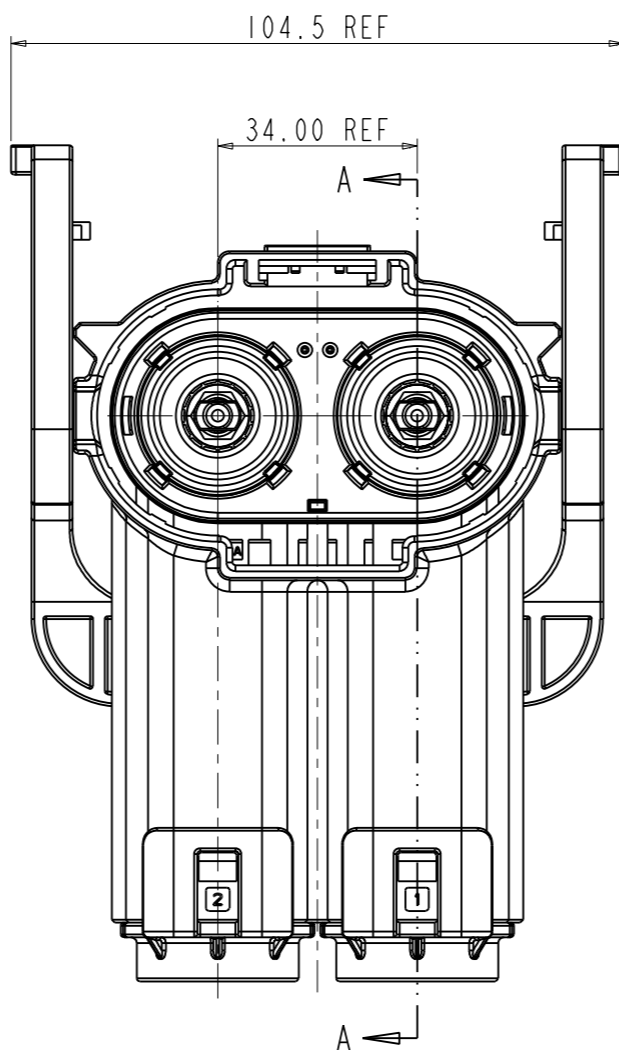

SECTION A-A

HVSLP1200 08 2 X X XX

A	A Key
B	B Key
C	C Key

95	95mm ² Cable
70	70mm ² Cable

0	WITHOUT HVIL
1	WITH HVIL

TECHNICAL DATA		SPECIAL CHARACTERISTICS SYMBOL
CURRENT RATE 95mm ² WIRE	400A	+
CURRENT RATE 70mm ² WIRE	300A	+
VOLTAGE RATE	1000V AC/DC	+
OPERATING TEMPERATURE	-40-125°C	NA
DIELECTRIC WITHSTANDING VOLTAGE	POWER PIN: 3000V AC	+
	SIGNAL PIN: 660V AC	
INSULATION RESISTANCE	>200MΩ(1000V DC)	+
DURABILITY	50 CYCLES	◎
SHIELDING	YES	NA
WATERPROOF (MATED CONDITION)	IP67 IP6K9K	+
CORROSION-PROOF GRADE(SALT FOG TEST)	96 HOURS	NA
AMBIENT TEMPERATURE	-40-70°C	NA
95mm ² CABLE SIZE(JACKET DIAMETER)	∅20.9+0/-0.8(LV216)	NA
70mm ² CABLE SIZE(JACKET DIAMETER)	∅18.2+0/-0.8(LV216)	NA
SIGNAL PIN CURRENT	5A	NA

DIMENSIONS	TOLERANCES	PROJECTION	TITLE		
ANSI Y14.5M UNITS: MM Pro/E FILE	.X ±0.5 .XX ±0.05 ANGLES ±2°		Amphenol PCD Shenzhen		
			Aug-31-21		
ORIGINAL	THIS DOCUMENT CONTAINS PROPRIETARY INFORMATION WHICH IS THE CONFIDENTIAL PROPERTY OF Amphenol PCD Shenzhen Co. Ltd Amphenol PCD Shenzhen Co. Ltd RESERVES THE RIGHT TO CLARIFY THIS DRAWING	CHKD	SIZE	DWG NO.	REV
		APPD	A3	C-HVSLP1200082XXXX	2
			CODE: 58982	SCALE: 4:5	SHEET 1 OF 3

C-HVSLP1200082XXXX

C-HVSLP1200082XXXX

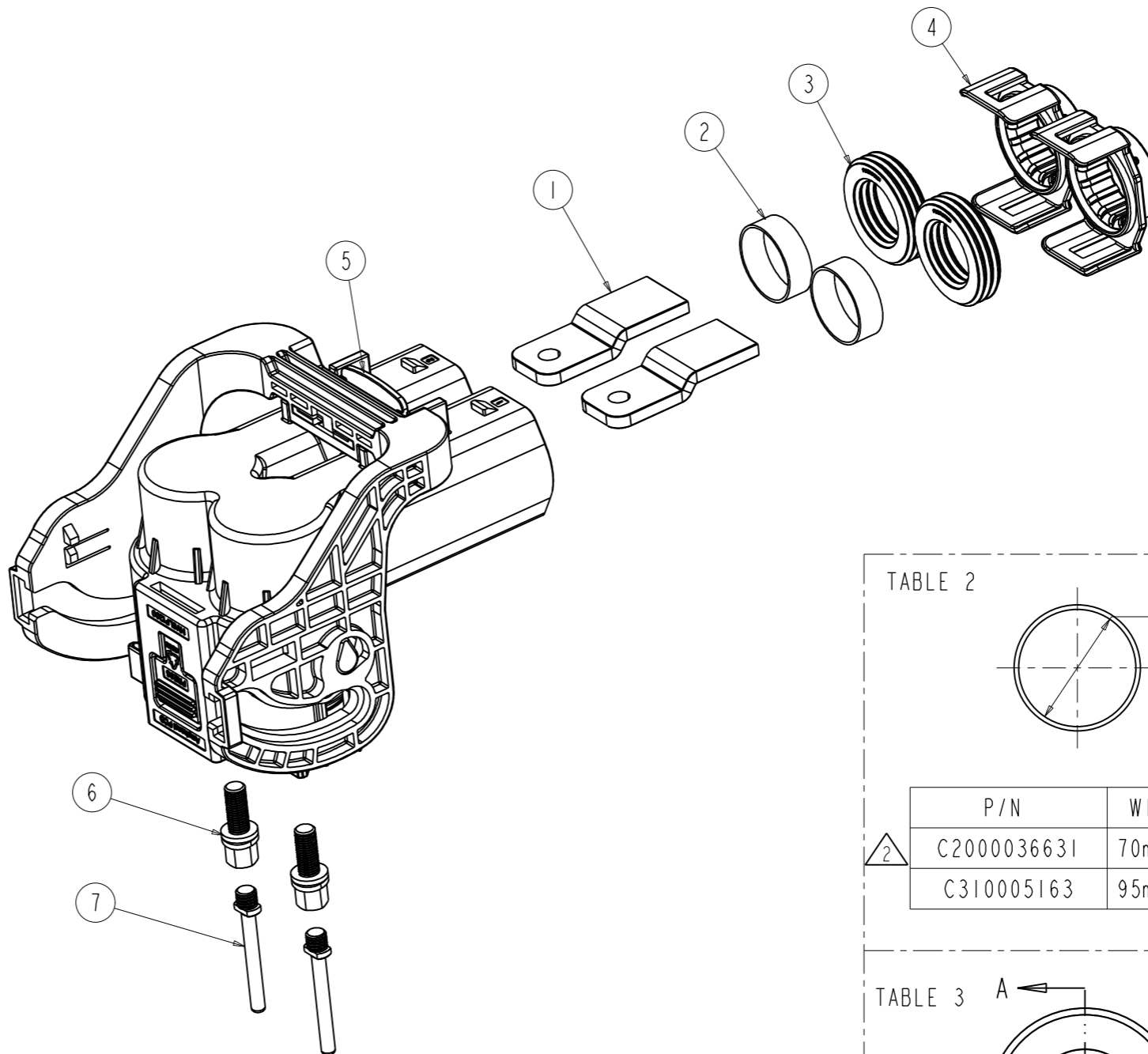
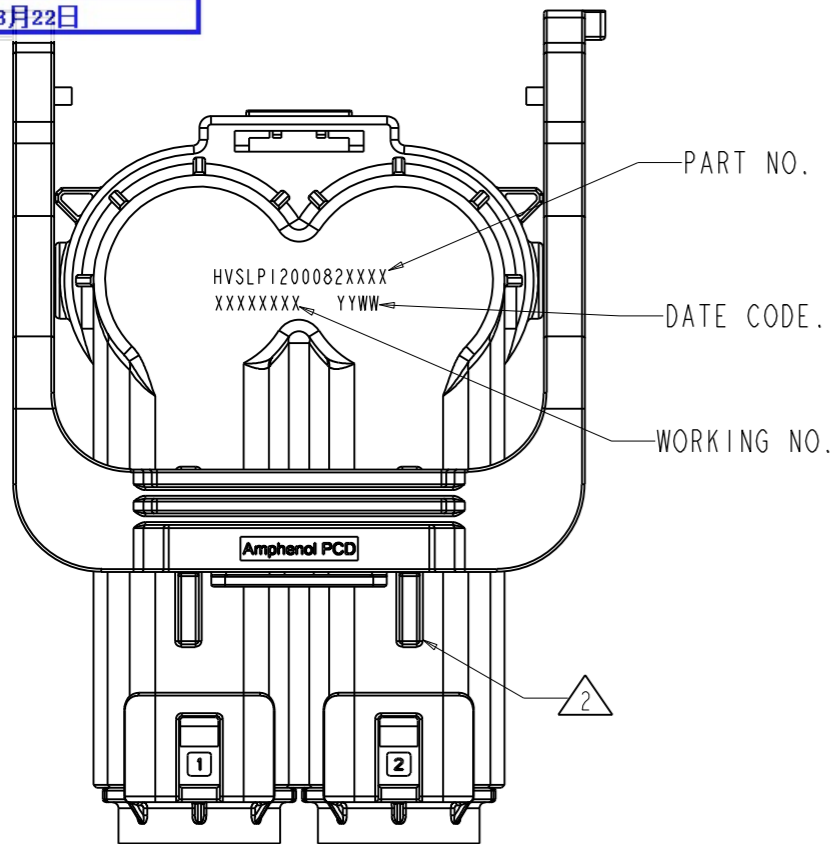

C-HVSLP1200082XXXX

C-HVSLP1200082XXXX

CONNECTOR ACCESSORIES LIST			
INDEX	P/N	DESCRIPTION	QTY
7	C220005386	FINGER TOUCH PROTECTION	2
6	POIBN00828	M6 MOUNTING SCREW	2
5	HVSLP1200082XY (X=A,B,C; Y=0,1)	PLUG RA BODY	1
4	SEE TABLE 4	PLUG END CAP	2
3	SEE TABLE 3	CABLE SEAL	2
2	SEE TABLE 2	SHIELD FERRULE	2
1	SEE TABLE 1	TERMINAL	2

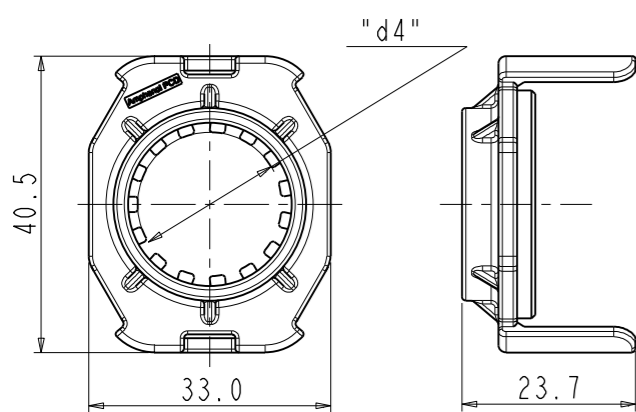

TABLE 4

P/N	WIRE SPEC	DIMENSION d4
P01BP0036301	70mm ² Cable	∅18.8
P01BP0036302	95mm ² Cable	∅21.5

TABLE 1

TERMINAL	P/N	WIRE SPEC	WIRE INSTALLATION
	P01BS0017102	70mm ² CABLE 95mm ² CABLE	ULTRASONIC WELDING

TABLE 2

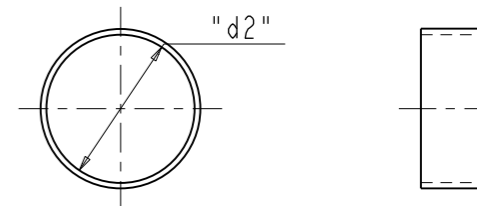

P/N	WIRE SPEC	DIMENSION d2
C2000036631	70mm ² Cable	∅18.7
C310005163	95mm ² Cable	∅22.4

TABLE 3

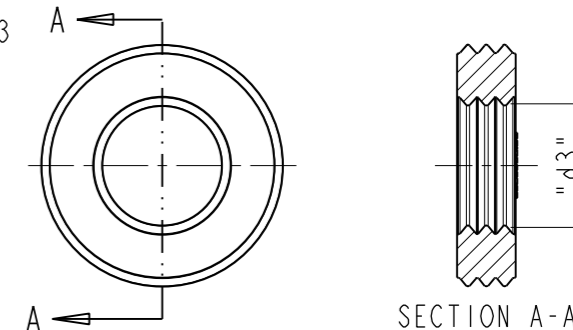

P/N	WIRE SPEC	DIMENSION d3
P01BR00290	70mm ² Cable	∅16.3
P01BR00291	95mm ² Cable	∅19.0

SIZE A3	DWG NO. C-HVSLP1200082XXXX	REV 2
CODE: 58982	SCALE: 4:5	SHEET 2 OF 3

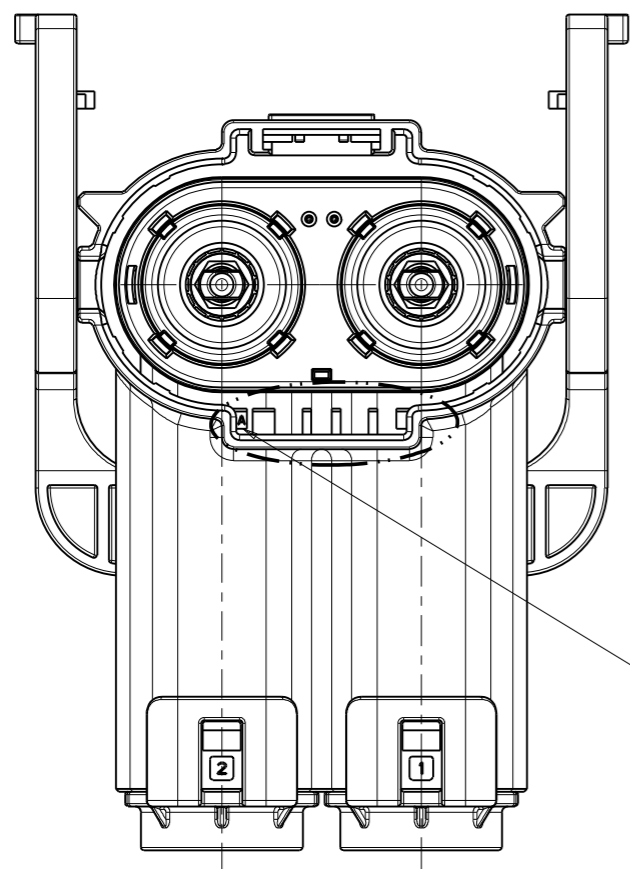

HVSLP1200082AXXX

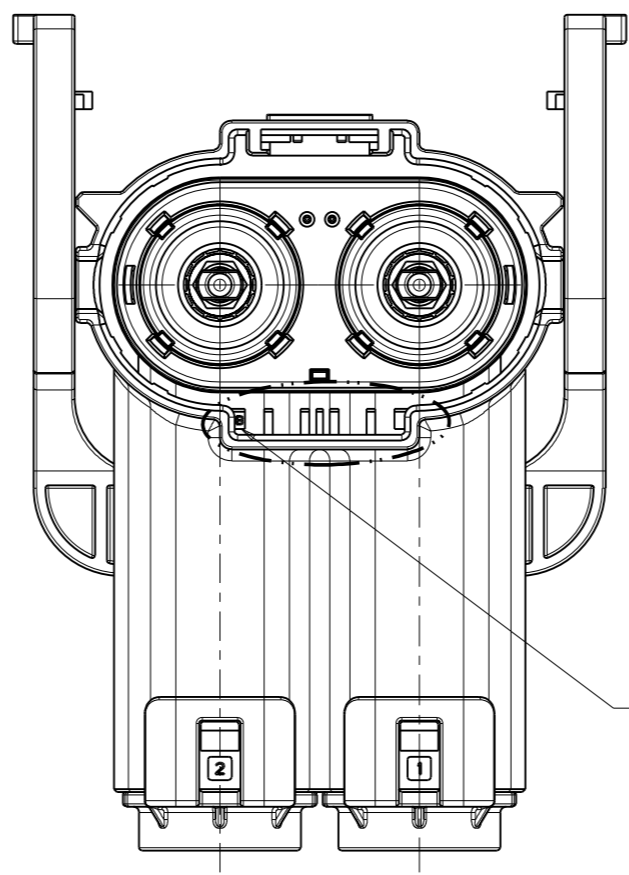

HVSLP1200082BXXX

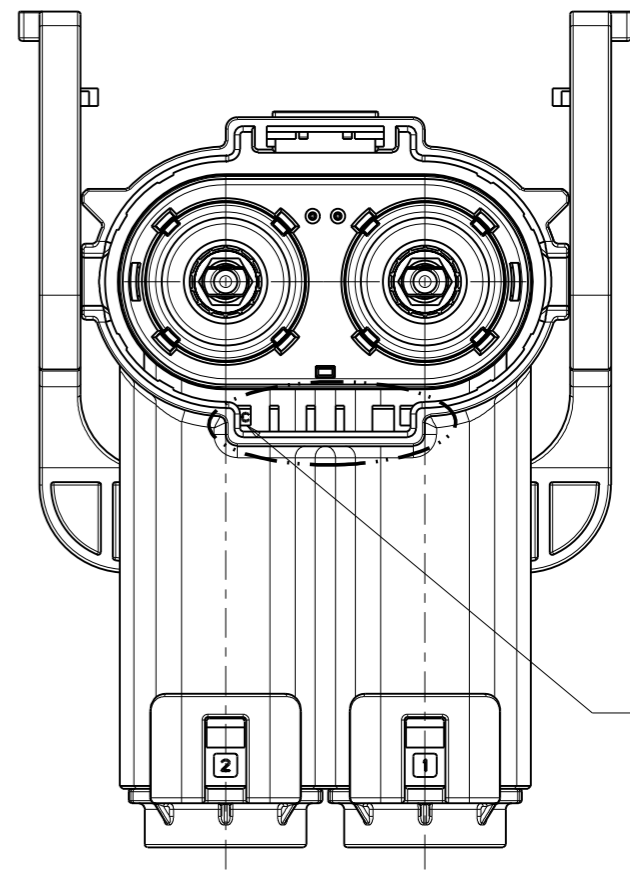

HVSLP1200082CXXX

C-HVSLP1200082XXXX

C-HVSLP1200082XXXX

SIZE	DWG NO.	REV
A3	C-HVSLP1200082XXXX	2
CODE: 58982	SCALE: 4:5	SHEET 3 OF 3