

Amphenol PCD Shenzhen
ORIGINAL
PDF Format
R&D

REV	ECN	DESCRIPTION	DATE	MODIFIED
1		RELEASE	Aug-24-2023	
2	R7378N	UPDATED MARKING	Oct-22-2023	
3	R7717W	UPDATE SHELL PRINTING&NOTE	Apr-10-2024	

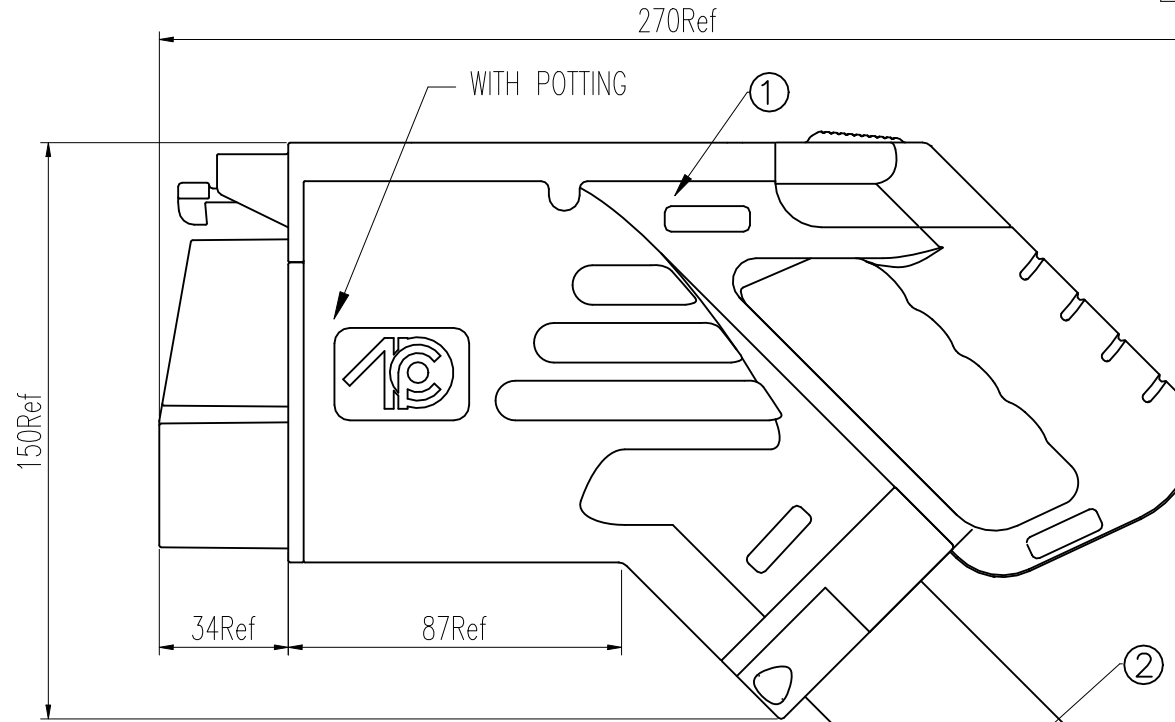
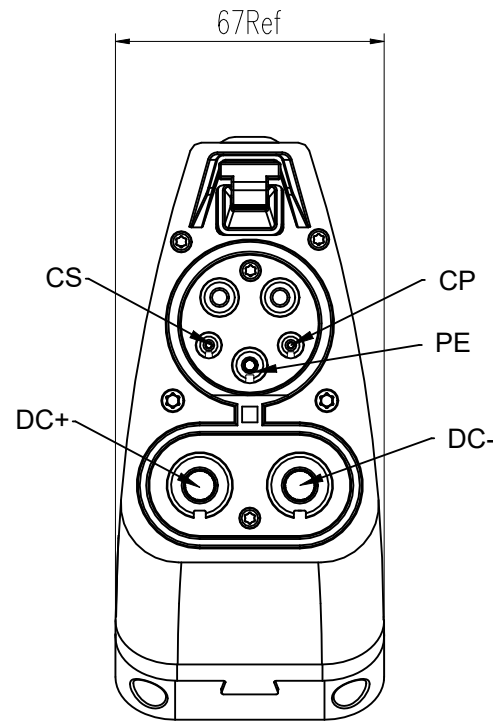

T / N: XXXXXXXX indicates the work order number
YYWW indicates year/week

Amphenol PCD

TYPE: HVCOSAEM350AML TYPE 3S T/N:XXXXXXXX YYWW
Rated . 350 A, 1000 Vdc . A&T:-40°C~+50°C
CAUTION:Not for current interrupting.
Connector is intended for use with Inlet Models type SAE J1772
CAUTION:Do not use if there is any damage to the EV cable or the connector XX

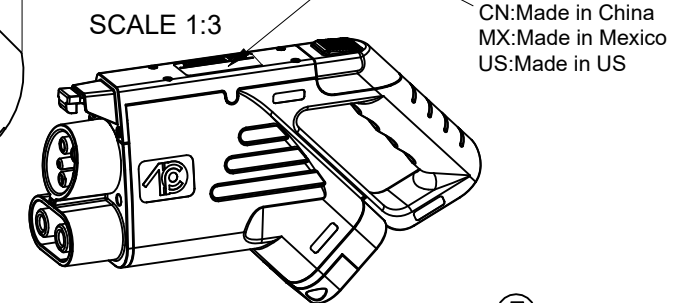

C-HVCOSAEM350AMLXXXX

C-HVCOSAEM350AMLXXXX

QR code Content including:
Part number#Work order number
#Serial number ex:0001
(ex:HVCOSAEM350AML5000#XXXXXX#0001)

Mode Of Connection:

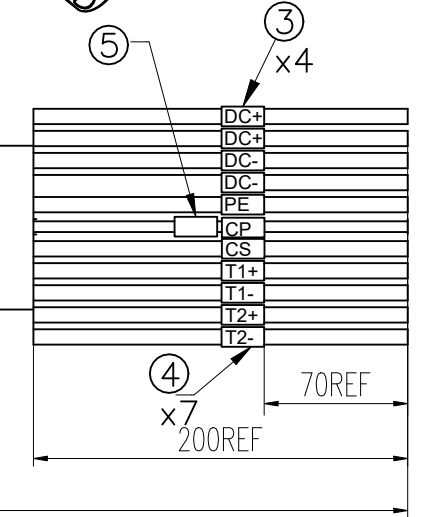
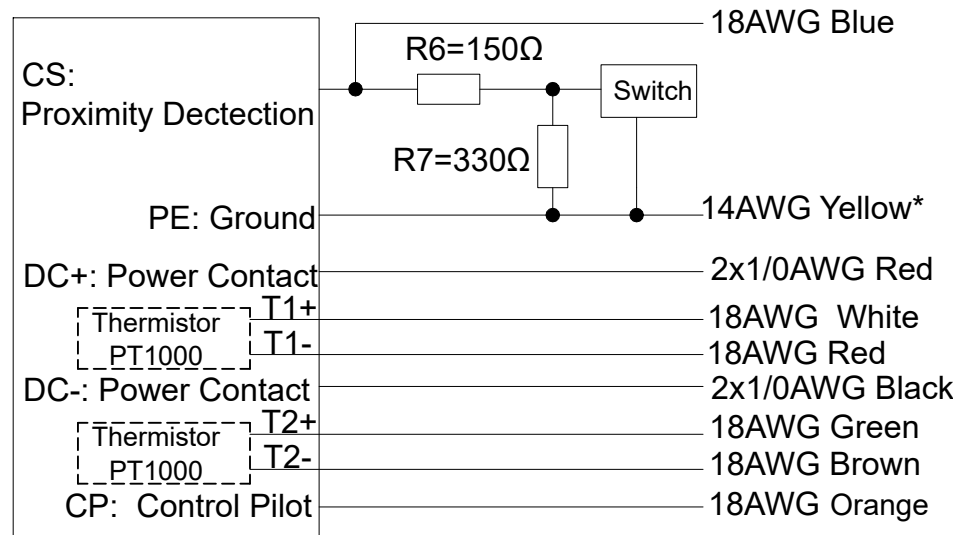

NOTES: 3

- Cable assembly data:
1>.Ambient Temperature: -40°C~+50°C,
2>.Rated Voltage & Rated Current:
CP, CS: DC 30V ,2A;
DC+,DC-: DC 1000V, 350A,the max permissible temperature is 90°C;
- Outdoor Use : UL Type 3S (Water resistant)
- The Type Of Temperature Sensor: PT1000
- Dielectric Withstand Voltage :
DC+,DC-,PE: 3000V AC r.m.s, CP&CS&thermistor wires:500V AC r.m.s
- Insulation Resistance Test: DC+/DC-&PE :DC1000V, 5MΩ MIN
CP&CS&thermistor wires:DC500V, 5MΩ MIN
- Reference For SAE J1772 ,UL2251
- RoHS Compliance
- Cable minimum bending radius:≥10XOD
- Weight of Cable: app 2870g/m
Weight of plug: app 1380g/m

LENGTH	TOLERANCE
0~1000mm	±50
1001~5000mm	±100
>5000mm	±200

⑤	C210006342	DOUBLE-WALL H.S.T: Ø4 BLACK	0.05	m
④	P05B000029/C210006837	SINGLE-WALL H.S.T: Ø3.2 WHITE	0.12	m
③	C210021010	SINGLE-WALL H.S.T: Ø14 WHITE	0.08	m
②	P01BC00285	4X1/0AWG+14AWG+6X18AWG BK OD36.5mm	AR	m
①	HVCOSAEM350AML0000	CCS1 PLUG 350A 1000V	1	EA

DIMENSIONS	TOLERANCES	PROJECTION
ANSI Y14.5M	.X ± 0.5	
UNITS: MM	.XX ± 0.05	
CAD FILE	ANGLES ± 2'	
ORIGINAL	THIS DOCUMENT CONTAINS PROPRIETARY INFORMATION WHICH IS THE CONFIDENTIAL PROPERTY OF Amphenol PCD Shenzhen Co. Ltd Amphenol PCD Shenzhen Co. Ltd RESERVES THE RIGHT TO CLARIFY THIS DRAWING	

ITEM	P/N	DESCRIPTION	QTY	UNIT
Amphenol PCD Shenzhen		TITLE	CCS1 PLUG 350A CABLE ASSEMBLY	
ENGR		Aug-24-2023		
CHKD	APPD	SIZE	DWG NO.	REV
		A3	C-HVCOSAEM350AMLXXXX	3
SCALE 1:1			SHEET 1 OF 1	

*- Ground wire is suitable for isolated DC EV supply equipment as reference earth or function earth.